

EFFER 35

Operator's Manual GB

This operator's manual is an Original Instruction valid for crane models EFFER 35 from serial number(s):

ME0003500001

2022-02

Congratulations!

You are now the owner of a quality Product manufactured by Hiab (part of Cargotec Corporation).

The aim of this manual is to help you handle, maintain your crane safely and with full satisfaction.

This Manual provides detailed information about your Product, its control systems and its practical management and maintenance.

Please read the complete Manual carefully and make sure that you understand its contents. Please also carefully familiarise yourself with your Product before you start to use it.



Help us to improve this manual. Please send your comments and suggestions to **contact@effer.com**

Table of Contents

| | |
|---|----|
| 1. Introduction | 5 |
| 1.1. Target group and scope of this manual | 5 |
| 1.2. The Machinery Directive 2006/42/EC | 6 |
| 1.3. Indications in the Operator's Manual | 7 |
| 2. Structure and parts of the crane | 10 |
| 2.1. Main groups | 10 |
| 2.2. Crane base with column and slewing system | 11 |
| 2.3. Stabiliser system | 11 |
| 2.4. Boom system | 12 |
| 2.5. Accessories on the boom system | 12 |
| 2.6. Operating system - hydraulic components | 14 |
| 2.7. LHV Load holding valves | 14 |
| 2.8. Description of the crane | 15 |
| 2.9. Accessories that can be fitted in an EFFER 35 | 15 |
| 3. Safety precautions and warnings | 16 |
| 3.1. Operating conditions | 16 |
| 3.2. Wind conditions | 17 |
| 3.2.1. Wind speed | 17 |
| 3.2.2. Load shape | 18 |
| 3.2.3. Working height | 18 |
| 3.3. Definition of this loader crane | 18 |
| 3.3.1. Noise declaration | 20 |
| 3.3.2. Signs on the crane | 20 |
| 3.3.3. Maximum load | 20 |
| 3.3.4. Maximum load | 24 |
| 3.4. Signals when using a crane | 26 |
| 3.5. Use of the crane | 30 |
| 3.5.1. Preparations for use | 31 |
| 3.5.2. Crane operation | 33 |
| 3.5.3. Driving with the crane | 35 |
| 3.5.4. Use of lifting equipment | 36 |
| 3.5.5. Use of demountable cranes | 37 |
| 3.5.6. Ending crane operation | 37 |
| 4. The Operating system | 38 |
| 4.1. Components of the operating system | 38 |
| 4.2. Description of the operating system | 38 |
| 4.3. Emergency stop buttons | 39 |
| 4.4. Standard symbols and functions of the crane | 39 |
| 4.5. Main control valve | 41 |
| 4.5.1. Crane with manual control station | 41 |
| 4.5.2. Crane with remote control [option] | 43 |
| 4.6. SCANRECO controller [option] | 43 |
| 4.6.1. Buttons, selectors and LEDs | 45 |
| 4.6.2. Standard functions and symbols | 47 |
| 4.6.3. Battery and battery charger | 48 |
| 4.7. Warning lamp and audible warning device [option] | 49 |
| 4.8. Pressure gauge | 49 |

| | |
|--|----|
| 5. Starting crane operation | 50 |
| 5.1. Starting operations | 50 |
| 5.2. Set the stabiliser system | 52 |
| 5.2.1. Stabiliser system and ground conditions | 52 |
| 5.2.2. Activate the stabiliser system | 53 |
| 5.2.3. Extend the stabiliser extensions | 53 |
| 5.2.4. Set the stabiliser legs | 54 |
| 5.3. Operate the boom system out of transport position | 55 |
| 5.3.1. How to operate the boom system | 56 |
| 6. During operation | 57 |
| 6.1. Hook assembly | 57 |
| 6.2. Controlling the crane speed with the controller SCANRECO [option] | 57 |
| 6.3. Pressure gauge | 58 |
| 6.4. Manual extensions [if installed] | 59 |
| 6.5. Hydraulic couplings [option] | 61 |
| 7. Ending crane operation | 63 |
| 7.1. Operate the boom system into transport position | 63 |
| 7.1.1. How to operate the boom system | 63 |
| 7.2. Placing the stabiliser system in the transport position | 64 |
| 7.3. Switching off the system | 66 |
| 7.4. Emergency operation | 66 |
| 7.4.1. Crane movements in an emergency | 66 |
| 7.5. Transport Warning | 67 |
| 8. Maintenance and Service | 69 |
| 8.1. Service | 69 |
| 8.2. Warranty | 70 |
| 8.3. Follow the maintenance instructions! | 70 |
| 8.3.1. Daily inspection | 72 |
| 8.3.2. Monthly inspection and maintenance | 76 |
| 8.3.3. Annual maintenance | 77 |
| 8.4. Lubrication | 77 |
| 8.4.1. General greasing of the cranes | 77 |
| 8.4.2. Lubrication schedule | 79 |
| 8.4.3. Lubrication of the upper and lower slewing bearing | 79 |
| 8.4.4. Lubrication of the boom system | 79 |
| 8.4.5. Grease on the stabiliser extensions | 81 |
| 8.4.6. Lubrication of the hooks | 81 |
| 8.5. Checking and topping up oil levels | 82 |
| 8.5.1. Oil tank / Hydraulic oil | 82 |
| 8.6. Replacement of filters | 84 |
| 8.6.1. Inlet filter for remote-controlled cranes | 85 |
| 8.6.2. Breathing filter | 85 |
| 8.7. Bleeding air from the hydraulic system | 85 |
| 9. Decommissioning | 87 |
| 9.1. Decommissioning a crane | 87 |
| 10. Technical Data | 89 |
| 10.1. Load plate table | 89 |
| 10.2. Identification of the loader crane | 90 |
| 10.3. Daily inspection checklist | 90 |
| 10.4. Monthly inspection checklist | 91 |

1. Introduction

1.1. Target group and scope of this manual

This manual describes:

- Operation
- Safety precautions and warnings
- The crane control system
- Maintenance and troubleshooting

Enclosed to this manual the Installer will provide:

- Technical Data for your crane
- Technical Data and manuals for add on equipment if fitted

Study these instructions carefully



DANGER

If you do not study the complete Operator's Manual for your crane carefully, it could lead to fatal accidents or serious damage.



NOTE

This manual gives instructions for a crane installed on commercial vehicles.

Therefore you should:

- Study the entire Operator's Manual carefully.
- Study the operating manuals for other add-on equipment, if fitted.
- Use the crane only after having done so.
- Follow the directions for use, operation and maintenance of the crane and add on equipment exactly.
- Store the Technical Data and manuals from the Installer, together with this Operator's manual.



1.2. The Machinery Directive 2006/42/EC

The diagram shows two versions of the Declaration of Conformity form side-by-side. The left version is in Italian, and the right version is in English. Numbered callouts (1-10) point to specific sections in both versions:

- 1:** Title and header information (Dichiarazione di conformità / Declaration of conformity).
- 2:** Model and serial number information.
- 3:** Statement of conformity with CE marking.
- 4:** Design reference standards.
- 5:** Name and address of the manufacturer (Effer).
- 6:** Identification of accessories.
- 7:** Manufacturer information (Grue / Crane).
- 8:** Vehicle identification information (Veicolo / Vehicle).
- 9:** Reference standards for installation (E conforme alla Direttiva / Complies to the Directive).
- 10:** Installer information (Luogo e Data / Place and Date).

| | | | |
|-----|--|------|--|
| (1) | The Declaration of Conformity delivered with the crane contains: | (6) | Accessories identification and data |
| (2) | Description and identification of the loader crane: | (7) | Description and identification of the loader crane by the installer: |
| (3) | <ul style="list-style-type: none"> Model Serial number Manufact. year | (8) | <ul style="list-style-type: none"> Manufacturer Model Serial number |
| (4) | Statement about the CE declaration | (9) | <ul style="list-style-type: none"> Vehicle identification by the installer Type and chassis number |
| (5) | Design reference standards | (10) | <ul style="list-style-type: none"> Installation reference standards Identification of the installer authorised to compile the technical file: Name Address Signature and position Place and date |

1.3. Indications in the Operator's Manual

What must you do and not do?

The following indications are used in the Operator's Manual:



DANGER

Danger to life for yourself or to bystanders.

Follow the instructions carefully!



WARNING

Danger of injury to yourself or to bystanders, or danger of serious damage to the crane or other objects.

Follow the instructions carefully.



CAUTION

Hazard for the crane or crane components. Follow the instructions carefully.

Important:

If actions are numbered

1. Do this
2. Do that
3.
4.
5.

you should carry them out in numerical order!



NOTE

Extra information that can prevent problems.



TIP

Tip to make the work easier to carry out.

The symbol for reference to a component in an illustration.

(1) Refers to a component in an illustration.

[option]: Indication for parts that are not standard for the crane, but are optional. Not all options are available for your crane.

Illustrations used in this manual are for guidance only, and the illustrations are provided to help identify the general area of a crane/installation referenced in the text.

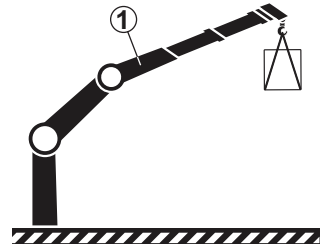

DANGER

Only persons with the requisite knowledge and experience with cranes may use the crane. Never operate the crane when you are sick, tired, under the influence of medicines, alcohol, or other drugs.

- Take the delivery instructions from your authorised service workshop, or receive instruction from an experienced person from your own company before you start to operate your crane.
- Make sure that you comply with the regulations of the country in which you use the crane (for example, certificate, safety helmet, and other personal protection devices).



DANGER

- Carry out yourself only the service and maintenance work you have the requisite knowledge and experience of.
- All other maintenance work may only be carried out by an authorised service workshop.
- Make sure that every defect is rectified immediately, according to the instructions.
- Follow the instructions exactly!
- All other work to rectify faults must be performed by personnel in an authorised service workshop!

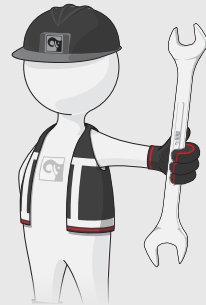

**WARNING**

- Never clean the electronic system, plastic components, signs, or bearings with a high-pressure jet cleaner. It could cause damage.
- Never expose the electronic system to high electrical voltages. This could damage the control system.
- Never immerse the controller in water or other liquid. This will make the controller unusable.

If your crane is equipped with add-on lifting equipment (hoist, rotator, etc.):

- The operation of the crane with add-on lifting equipment can differ from the operation as described in this manual.
- You should therefore study the Operating Manual for the add-on equipment carefully before you use the crane.
- Take particular note when placing the crane into or out of the transport position.

2. Structure and parts of the crane

2.1. Main groups

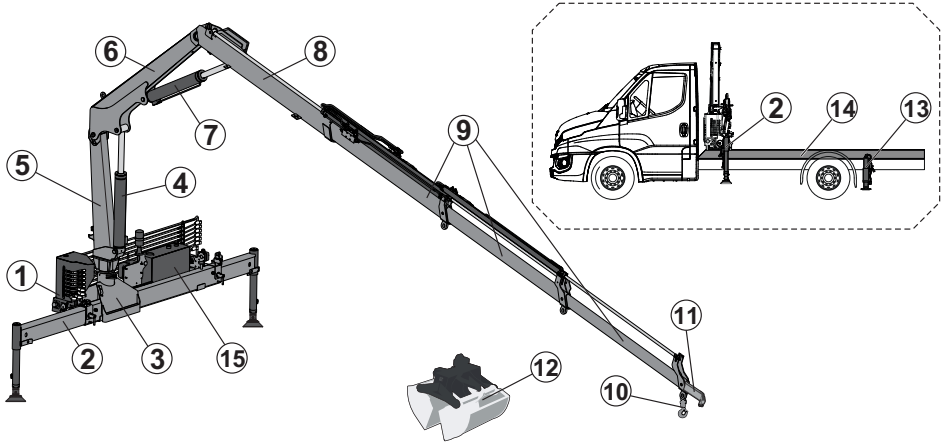

This crane consists of the following main groups:

- | | | |
|-------------------------------|-----------------------|----------------------------|
| (1) Control station | (6) 1st boom | (11) Manual extension |
| (2) Stabiliser system | (7) 2nd boom cylinder | (12) Accessories |
| (3) Base / Three-point bridge | (8) 2nd boom | (13) Auxiliary stabilisers |
| (4) 1st boom cylinder | (9) Boom extensions | (14) Subframe |
| (5) Column | (10) Hook | (15) Oil tank |

Some accessories can be attached depending on your crane configuration:

- Manual extensions [option]
- Add-on lifting accessories [option]
- Hooks [option]
- Separate lifting accessories [option]

2.2. Crane base with column and slewing system

The crane base, column, and slewing system consist of the following components:

- (1) Crane base
- (2) Stabiliser beam
- (3) Column
- (4) Rack and pinion slewing system

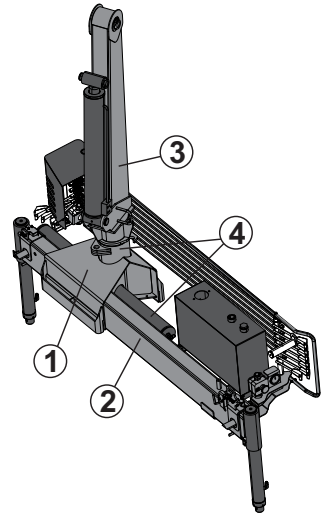

2.3. Stabiliser system

EFFER cranes have two stabiliser extensions and two stabiliser legs. Auxiliary stabiliser systems may be needed. The stabiliser system consists of:

- (1) Stabiliser beam
- (2) Stabiliser extensions
- (3) Stabiliser legs
- (4) Stabiliser locking devices
- (5) Extra support plates [option]

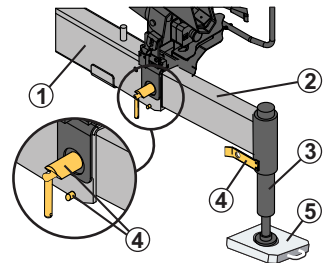

2.4. Boom system

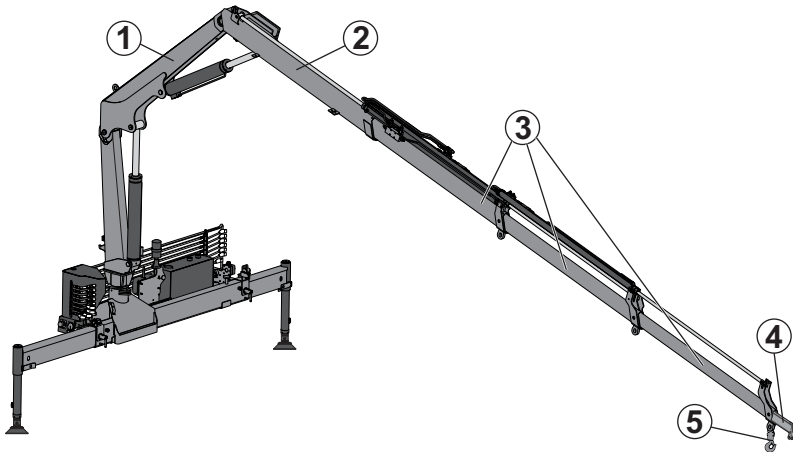

The boom system consists of the following components:

- (1) 1st boom
- (2) 2nd boom
- (3) Hydraulic extensions:
The length of the hydraulic extension depends on the type of crane.
- (4) Manual extensions [option]
- (5) Hook [option]

2.5. Accessories on the boom system

Manual extensions [option]

The manual extension is slid by hand into the hydraulic extension.

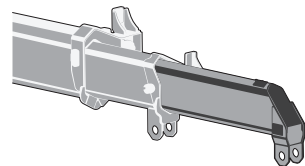

Add-on lifting accessories [option]

Add-on lifting accessories are placed between the boom tip and the load (e.g. brick grapple, rotator) or on the crane (e.g. hoist).

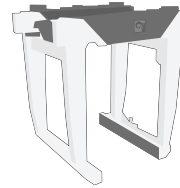

Hooks [option]

Different hooks can be mounted depending on the crane model.



DANGER

Never exceed the maximum permissible loading of the hook.

Separate lifting accessories [option]

Separate lifting accessories, help to make or use a slinging device: shackles, eye-bolts etc.



2.6. Operating system - hydraulic components

The operating system consists of the following hydraulic components:

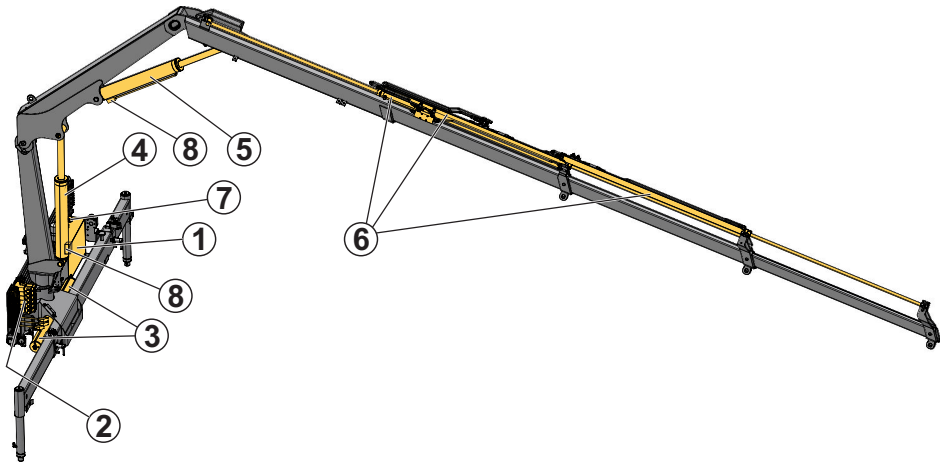

| | | |
|------------------------|--------------------------|---------------------------|
| (1) Oil tank | Actuators: | (7) Return filter |
| (2) Main control valve | | (8) Load holding valve |
| (3) Slewing cylinders | (4) 1st boom cylinder | Hydraulic pump |
| | (5) 2nd boom cylinder | Hydraulic hoses and lines |
| | (6) Extension cylinder/s | |

2.7. LHV Load holding valves

All cylinders are equipped with load-holding valves as a safety device. After a crane movement, they hold the crane in position, also in the unlikely event of a burst hose.

If there is a leak or a component fractures, such as a pipe, hose or coupling, the load-holding valves will stop the booms from collapsing down, even when the hydraulic system is switched off, and you operate a particular crane lever.

To operate a hydraulic cylinder equipped with a load holding valve, an opening pressure is required.

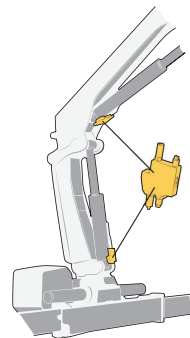

**DANGER**

It is not permitted to manipulate these devices because you can cause serious accidents.

Only an authorised service workshop can do the servicing, replacement and/or repair of these valves.

2.8. Description of the crane

The loader cranes EFFER 35 are compact, fully hydraulically operated goods cranes and fulfil the European Machinery Directive requirements specified in the standard EN 12999.

Stress class HC1-S1-HD4 according to EN 12999.

Maximum lifting capacity:

- EFFER 35 = 3.01 tonne metres

The crane is supplied in many versions from:

- EFFER 35-1S (reach 4.75 metres) to EFFER 35-3S (reach 7.80 metres)

The control valve WALVOIL and the controller SCANRECO [option] are standard equipment on this model.

The crane type and the manufacturer are marked on the serial number plate.

**NOTE**

The exact technical information for your crane is shown in the Technical Data.

2.9. Accessories that can be fitted in an EFFER 35

| Manual extensions | available in combinations: |
|-----------------------------|----------------------------|
| 1 manual extension in crane | 35 1S/2S + 1 |

**NOTE**

Other manual extensions in crane are available for non-CE markets.

3. Safety precautions and warnings

3.1. Operating conditions

You may use the crane **ONLY** if:

- You are outdoors or in a space with sufficient ventilation.
- The mean wind velocity is less than 10.7 m/sec (approx. 38 km/h or 24 mph). **Refer to the wind speed tables.**
- Operational temperature range is between -20°C and +40°C.



DANGER

- **Do not use** the crane in a confined space because you could suffocate from the exhaust gases from the vehicle.
- **Never** use the crane in a high wind or storm. When the mean wind velocity exceeds 10.7 m/sec (approx. 38 km/h or 24 mph), the crane will behave unpredictably. **Never** use the crane during a thunderstorm.
- **Never** use the crane at temperatures below -30°C (-22°F), as the steel's properties deteriorate below this temperature.



WARNING

- At temperatures below 0°C (32°F), do not touch the operating levers during the first few minutes.
- In cold weather, the wear on the hydraulic system is greater than at normal working temperatures.

In cold weather, start the crane as follows:

- Engage the power take-off at low rpm.
- Allow the system to idle for a few minutes.
- Operate the stabiliser legs up and down to reach an oil temperature between 10°C and 15°C. Make sure that the temperature is between these values on the oil tank thermometer.



3.2. Wind conditions

The force of the wind causes stress on the structure independently of its direction.

The main factors that have an effect on the strength of the wind acting on the crane/load are:

1. Wind speed
2. Load shape
3. Working height

3.2.1. Wind speed

Refer to the table below to correctly identify the wind speed.

Wind speed averaged over 10 minutes at a height of 10 m

| Wind Force | Above flat ground | | Characteristics |
|------------|-------------------|--------------------|--|
| | m/s | Wind type | |
| 0 | 0.0 - 0.2 | Calm | Calm, smoke rises vertically or nearly vertically |
| 1 | 0.3 - 1.5 | Slight breeze | Wind direction recognisable from smoke plumes, the wind begins to be noticeable on the face; leaves begin to rustle and weather vanes can start to move. |
| 2 | 1.6 - 3.3 | | |
| 3 | 3.4 - 5.4 | Moderate wind | Leaves and twigs in continuous movement, small branches begin to move. Dust and paper begin to move over the ground. |
| 4 | 5.5 - 7.9 | | |
| 5 | 8.0 - 10.7 | Fairly strong wind | Small leaved branches make swaying movements; crested waves form on lakes and canals. |
| 6 | 10.8 - 13.8 | Strong wind | Large branches move; you can hear the wind whistling in telephone wires; umbrellas can only be held with difficulty. |
| 7 | 13.9 - 17.1 | Severe wind | Entire trees move; the wind causes difficulty when you walk into it. |
| 8 | 17.2 - 20.7 | Stormy wind | Twigs break off, walking is difficult. |
| 9 | 20.8 - 24.4 | Storm | Causes superficial damage to buildings (chimney pots, roof-tiles, and TV antennae are blown off). |
| 10 | 24.5 - 28.4 | Severe storm | Uprooted trees; considerable damage to buildings etc. (occurs infrequently on land). |
| 11 | 28.5 - 32.6 | Very severe storm | Causes extensive damage (occurs very infrequently on land). |
| 12 | > 32.6 | Hurricane | |

**NOTE**

Conversion to different measurements units:

- 1 m/s = 3.6 km/h
- 1 m/s = 2.24 mph

3.2.2. Load shape

The downwind area of the lifted load can cause an unwanted effect on the behaviour of the crane. Also, the shape and weight of the lifted load can have a greater effect on the forces involved.

Shape: different shapes have different wind effects. For example, a cylindrical shape load has a different wind resistance than a rectangular panel shape load.

Weight: a heavy load has a smaller effect by the wind force compared to a lighter load.

**WARNING**

Pay careful attention when operating the crane if the shape and the load can cause the sail effect due to the wind.

Always maintain eye contact when operating the crane.

3.2.3. Working height

The wind speed increases according to the height.

**WARNING**

Pay careful attention when operating the crane in vertical positions with the boom system fully extended.

Always maintain eye contact when operating the crane.

3.3. Definition of this loader crane

Usage of the crane

The loader crane is used to lift and move loads in the working area permitted by the load plate and the load diagram. The cranes are normally mounted on a vehicle. The crane can be equipped with a number of accessories.

Loader cranes are designed for loading and unloading the vehicle, as well as for other duties as specified:

Permitted duties:

- Loading and unloading cargo from/to a vehicle
- Lifting of loads from the ground/vehicle to a higher place
- Installation work (beams, concrete plates, windows...) in building constructions
- Lifting construction material (wall boards, bricks, blocks...) on a pallet fork to a building, taking the material from the vehicle on which the crane is mounted, from another vehicle or from the ground

- Hoisting, e.g. beams, concrete plates and any other material and equipment used in building construction
- Moving filling material at a construction site with a bucket
- Handling large loads (containers, boats, machinery, vehicles...)
- Collection of waste and recycling material (glass, paper, cardboard, plastic...)
- Installation of informative posts, road signs, notice boards, traffic lights, street lights...

Forbidden duties:

- Crane mounted onboard ships or floating structures, only permitted in cases authorised by Effer
- Continuous use as a production crane in assembly lines, foundries..., except for cranes prepared for that purpose
- Handle loads, work with submerge boom system or accessories, in strong currents such as rivers
- Pressure against the ground, unless the crane is specifically prepared for this
- Pushing/pulling with the boom system against any type of obstacle (wall, ground...)
- Putting loads on structures if you do not know their resistance
- Lifting loads with the wrong side of the boom system

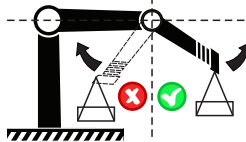

- Lifting a mass that is partially loaded or attached to another equipment/structure/element

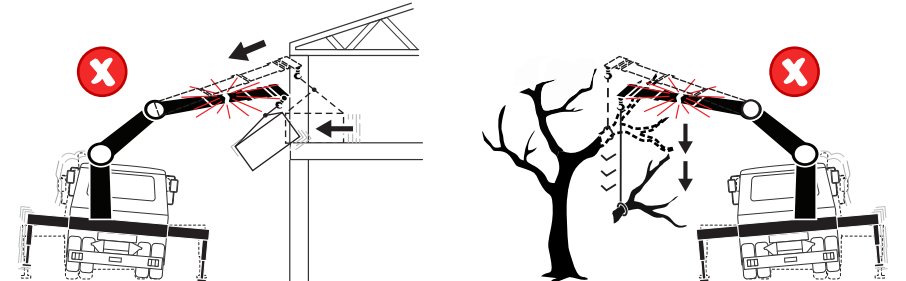

CAUTION

There is a risk of tipping the truck and/or damaging the crane, the load or other structures inside the working area.



DANGER

Lifting people with a crane is never allowed unless it is a MEWP crane.

3.3.1. Noise declaration

The following values for emitted noise may be taken as general and conservative values for ordinary installations of loader cranes on normal diesel engine powered trucks. Declared dual-number noise emission values in accordance with ISO 4871:

- Emitted A-weighted sound power level for basic loader cranes in accordance with ISO 3744: LwA = 103 dB (Uncertainty: KwA = 2 dB).
- Emitted A-weighted sound power level for loader cranes with hoist in accordance with ISO 3744: LwA = 107 dB (Uncertainty: KwA = 2 dB).
- A-weighted sound pressure level at loader crane control stations in accordance with ISO 11201: LpA = 95 dB (Uncertainty: KpA = 4 dB).

Particular installations can be quieter, in which case a post installation noise measurement in accordance with clause 6.3 of EN 12999 may be used to prove this.

3.3.2. Signs on the crane

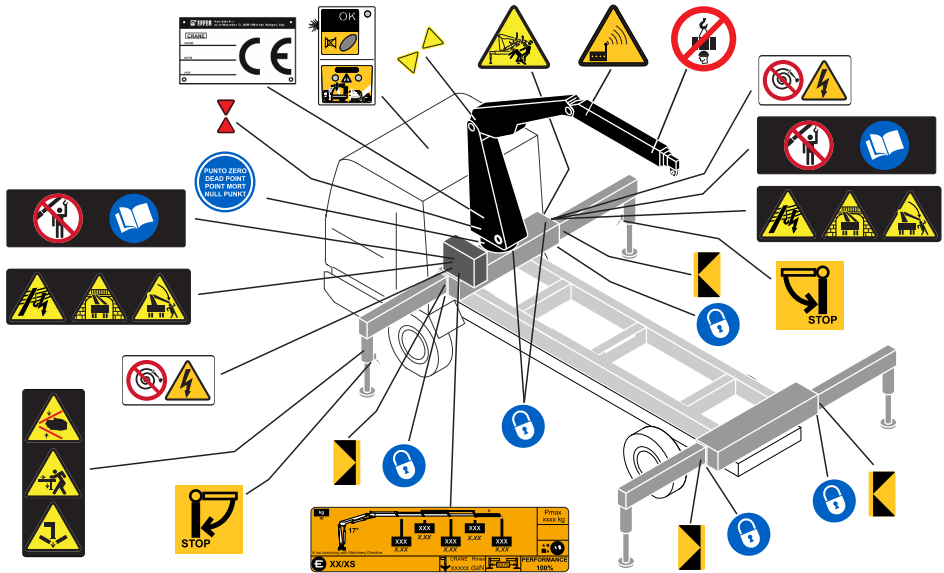

3.3.3. Maximum load

Lifting capacity

Your crane has a certain lifting capacity, expressed in kNm or tm. This lifting capacity is also known as the load moment. The lifting capacity is: the payload at hook multiplied by the outreach in metres that the crane can operate at different positions. The lifting capacity of your crane determines the maximum load your crane may lift within its working zone. However take careful note; the greater the operating radius of the crane, the lower the lifting capacity will be because of the weight of the boom system itself. The load plate and the load diagram on your crane show the maximum loads you may lift in the operating reach of your crane.



DANGER

- Overloading could result in damage to the crane or in the worst case, personal injury or death
- Never increase a hanging load, since that may cause a load holding valve to open and/or the vehicle to turn over.



NOTE

The lifting capacity shown in the standard crane load chart does not include the weight of the hose reel, grapple, manual extensions and any other accessories fitted on the boom system.

Load plate

On the plate, you read about the maximum weight that you can lift at a given outreach, with the 1st boom in the optimum position. In the Technical Data, you will find these values for your specific crane at different positions.

- (A) The maximum capacity of the crane.
- (B) The maximum load that the stabiliser leg can apply to the ground.
- (C) The position of the stabiliser extensions according to the load plate.

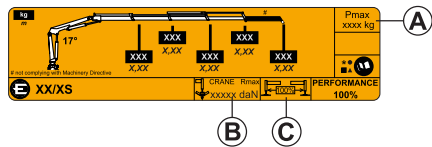

NOTE

Align the yellow arrows signs located on the column and on the 1st boom to reach the maximum load values as the load plate shows.

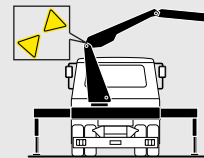

Optimum position

The weight that your crane can lift will be determined by:

- Stability test of your crane on the vehicle.
- Stabiliser extensions position and legs pushed on the ground.
- The reach at which you are working and the optimum position of the boom (the optimum position for your crane is on the load plate).



DANGER

- **DO NOT** lift more than the maximum weight shown on the load plate.
- This crane model does not have a stability control device. You, as the operator, are responsible to make sure that the vehicle is stable when you lift a load and that you do not lift more than the maximum load.

Load diagram

The load diagrams show the maximum loads that your crane may lift in all of the working area (manual extensions excluded). The load diagram is also in the Technical Data.

The load curves show the maximum load that your crane may lift at a given outreach and height. For a given maximum load, the permitted working area is on the left of the load curve.

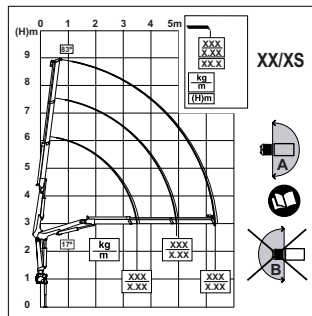

DANGER

The curves on the load diagram for **cranes without load limiter device** are arcs of a circle. For this reason:

- You must not extend the extensions at the same time that you lift or lower a load.
- You must not extend more than the curves on the load diagram.

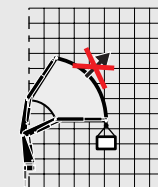

Working areas

The crane work as follow.

- **Area (A)**

In this area, the crane has maximum operating performance according to the load diagrams. The crane operates with the same lifting capacity for the whole working sector (190°).

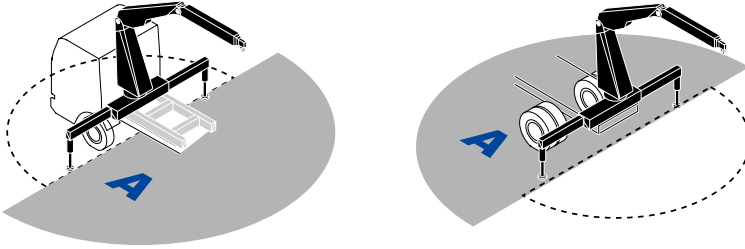

- **Area (B)**

In this area, operation is permitted only by the installer. If the installer does not supply such approval, the crane operation in this area is not permitted.

The type of installation can have an effect on the performance of the crane.

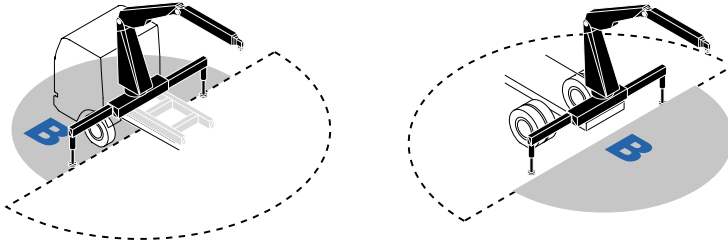

WARNING

On the CE cranes, there is a mechanical device (C) to prevent the crane operation in working area (B).

Only the installers, on their own responsibility, can remove this mechanical device (C).

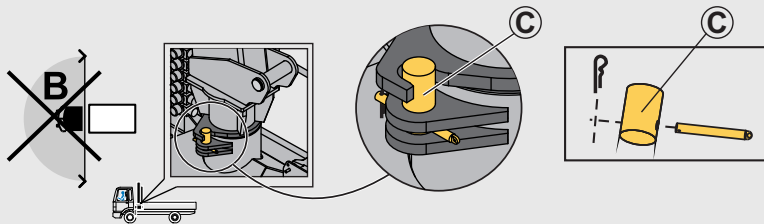

**WARNING**

Be careful when you operate loads in the high lifting area, as the load/tool must not touch the boom system.

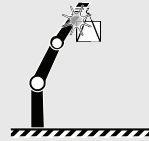
**WARNING**

Never operate the hydraulic extensions against a solid object when the first boom is completely lifted. Do not try to push or compress loads when the first boom is fully lifted, as this could cause damage to the first boom cylinder.

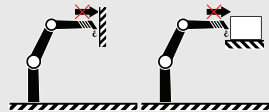
**3.3.4. Maximum load****DANGER**

Your crane has not a load control system!

You remain responsible for safe use of the crane!

Therefore, always work according to the operating instructions!

Lifting the load

Make sure that you always have the work in clear view. If you cannot see the load properly, you could cause a fatal accident or serious damage.

Sling length

Always attach the load using the shortest possible sling. The angle between the legs of the sling must not exceed 120° . The maximum working load, (usually known as the working load limit (WLL) in standards) of a multi-legged sling for general purposes, is calculated by multiplying the WLL of a single leg by a mode factor (refer to the table).

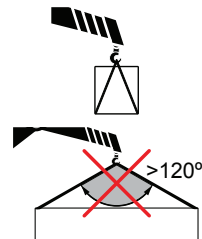

| Max angle to the vertical of any sling leg (degrees) | Mode factor two legged sling | Mode factor three and four legged sling |
|--|------------------------------|---|
| 0-45 | 1.4 | 2.1 |
| 45-60 | 1.0 | 1.5 |

If the angle between the legs of the sling is more than 90°, do not hang the slings directly on the hook. Use a ring hanging from the hook to attach the sling.



NOTE

These instructions do not replace the instructions provided by the chain manufacturer.

Working close to the load

Always try to lift the load with the extension boom retracted, however not completely. The crane then has the greatest lifting capacity. Place the vehicle as close as possible to the load.

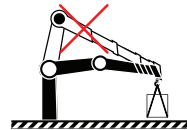

Working below ground level

If you have to load or unload below the level of the ground: keep the 1st boom angle to about 10° to 30° above the horizontal plane.



CAUTION

Do not operate the first boom down at the end of stroke (as in the picture).

In this position, cylinders could suffer overpressures or mechanical damages, and as a consequence, the load could fall and cause damage to the crane and/or the adjacent area or, in the worst case, personal injury or death.



Heavy loads

Lift heavy loads with the 2nd boom in the optimum position in relation to the 1st boom. For this, see the load plate on your crane.

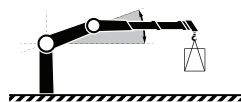

DANGER

Never exceed the maximum permissible loading of the hook.

Heavy loads cannot be handled with the boom straight.

Set the 2nd boom, so there is an angle in relation to the 1st boom.

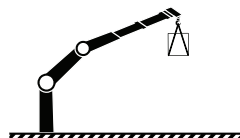

Loads at the extreme limit of the working zone

Also in this case, angle down the 2nd boom somewhat. Only use the 1st boom .



TIP

Make smooth crane movements: operate the crane with various functions simultaneously. In this way you will also prevent the hydraulic system heating up quickly.

3.4. Signals when using a crane



DANGER

- If it is not possible to see the load and the entire working area clearly, the crane operator must follow the instructions and signals given by a qualified person.
- The country-specific regulations for crane operator signals are to be used.

Signals in this manual give a number of standard signals that can be used.

Lift

Raised arm and index finger raised. Circular motion with the hand.



Lower

Arm pointing downwards and index finger down. Circular motion with the hand.



Stop all crane movements / Hold the load in position

Raise the open hand, with the palm clearly visible, and arm at shoulder height.

Keep the hand still.



Emergency stop for all movements by the crane

Raise the hands and the arms to an oblique angle.



Very short movement

Place the hands a very short distance apart, with the palms facing each other. The hands may be held either horizontally or vertically. The next movement may be: Lift, lower, move the lifting gear, change the reach, or turn.



Change the reach

Signal with your hands.

- Sideways movement outwards with both hands. Thumbs outwards.
- Sideways movement inwards with both hands. Thumbs inwards.

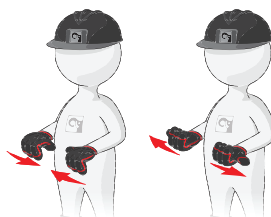

Turn in the direction indicated

Indicate the direction with the hands.

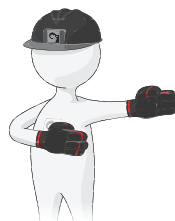

Open the tool

Extend the arms at shoulder height, with the palms facing downwards.

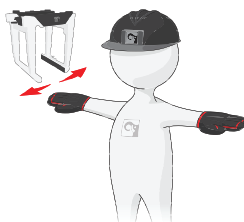

Close the tool

Move both hands close together.

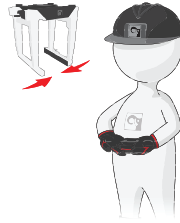

Lift the open tool a little

Extend both arms at shoulder height, with the palms facing upwards. Make vertical movements with both arms outstretched.

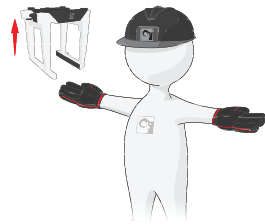

Keep the tool in position briefly

Raise the hand drooping slightly, with the fist clenched.



3.5. Use of the crane

Starting crane operation



DANGER

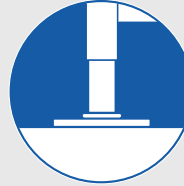

- Make sure that you comply with the regulations of the country in which you use the crane (for example, certificate, safety helmet, and other personal protection devices).
- Check that the ground is sufficiently flat and firm.
- Verify that the ground is not uneven. Be careful with sewers, cellars, excavations etc.
- To make sure that the vehicle stays in its position, always engage the parking brake and place chocks under the wheels.
- Lower the stabiliser legs only on to a flat and firm surface.
- Do not lower the stabiliser legs on the edge of an embankment, soft shoulder, slope etc.
- Make sure that you can see the stabiliser legs and stabiliser extensions when you are operating them.
- The stabiliser legs must not sink in! Use support plates that are large and firm enough for your crane. The plates must not bend because of the load weight.
- Verify that the support plates do not sink as you gradually lift the load.



DANGER

- Never use the stabiliser legs as a parking brake, since the vehicle could start to slide.
- Slide the stabiliser extension, on both sides of the vehicle, completely out. Then lower the stabiliser legs for support.
- Never operate the stabiliser legs/ extensions if there is a load suspended from the crane.





WARNING

- Use low force when you put the stabiliser legs on the ground.
- Do not raise the vehicle with the stabiliser legs! If you do, you can cause damage to the stabiliser legs.
- Check that the add-on lifting accessories and separate lifting accessories are in good condition!
Add-on lifting accessories are sometimes attached to boom tip (grapple, rotator).
Separate lifting accessories are connected to the standard load hook (slings, chains, shackles etc).



DANGER

Do not stand in front of the boom system when operating the crane out of transport position.

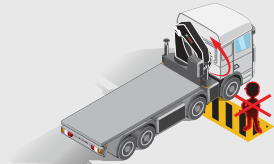

3.5.1. Preparations for use



DANGER

Make sure that there are no unauthorised persons within the operating range of your crane!

To mark the working area correctly, think about the space that the crane will need to lift the load (direction of the lift, size of the load).

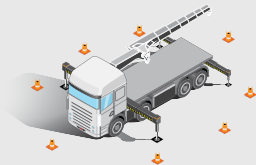

CAUTION

- Put on your vehicle's warning lights.
- Make sure that the parked truck does not block emergency exits, pedestrian roads or no-parking zones unless you have permission.
- Make sure that both the truck and the crane do not block the visibility of important signs for other users of the area (for example, road signs).



DANGER

- If a part of the crane comes in contact with an electricity line, you will be electrocuted!
- Always keep the following minimum distances between the crane and overhead electricity lines, unless otherwise prescribed by national rules.

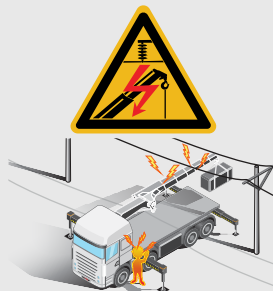

Minimum distance between crane and overhead electricity lines

| Voltage (V) | Minimum distance to an insulated conductor | Minimum distance to an uninsulated conductor |
|----------------------------|--|--|
| <500 V | 0.5 m | 2 m |
| 500-40000 V | 1.5 m | 4 m |
| >40000 V | 2.0 m | 6 m |
| Voltages are found: | | |
| up to 500 V: | | to buildings |
| 500-40000 V: | | trams, trains |
| over 40000 V: | | power transmission |



DANGER

When you go into the control station and during operation remove all jewellery, loose clothing, or other hanging items from your body (for example, rings, scarfs, bracelets...). Jewellery, loose clothes, and other hanging items can be caught in some parts of the crane.



WARNING

Make sure that you know the position of all the emergency stop buttons on your crane and on the controller.

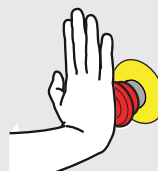

3.5.2. Crane operation



DANGER

Your crane has not a load control system!

You remain responsible for safe use of the crane!

Therefore, always work according to the operating instructions!

In an emergency situation, push immediately any of the emergency stop buttons. This will stop all crane movements and prevent the free movement of the load.



DANGER

- Keep checking that there are no unauthorised persons within the operating reach of the crane!
- Make certain that you can always see the load!

If your view of the load is not adequate, have someone else give you signals.

See the list of signals. Make certain that you and the person assisting you know these signals.

- Pay attention to the safety of the person giving the signals!
- Never move the vehicle, if you have a freely-suspended load on the crane!
- Never walk or stand under a suspended load!

During operation, never stand below the boom system or load!

- Do not slew the crane, nor lift the first boom, nor lift the second boom into their ends positions at full speed. This can damage the crane.





WARNING

- Never push a load along the ground, or the vehicle's load space, with the extension boom. This can cause damage to the boom system. This will lead to expensive repairs.
- Never use the extension boom as a jack. This could damage the slewing bearings and the connection between the crane column and the crane base.
- Always lift the load from the ground before you start to slew. Do not tow the load over the ground. This can damage the boom system.
- If you are working with loads in restricted spaces (for example, windows):
Check that the boom system can move up and down freely.
The boom system will bend somewhat, when loading and unloading the crane.
- If the boom system is in a high position (first boom above 70°), do not allow the boom to lower at full speed. The crane could go into an uncontrolled movement.

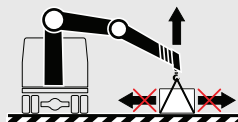

CAUTION

- Operate the crane using smooth and gentle lever movements.
- Pay attention to avoid hitting truck part and stabiliser legs and causing an accident during the crane operation.
- If a cylinder is at its end position, free the operating lever. Otherwise overheating can occur.



TIP

To prevent damage to your crane, we recommend that you do not leave the load hanging on the hook for a long time. Always leave the (load/tip of the crane) resting on a stable surface before a break or park the crane.

3.5.3. Driving with the crane



DANGER

- Never move/drive the vehicle if there is a load suspended from the crane.
- Before you move the vehicle:
Check that there is no pump flow to the main control valve. The PTO or power supply must be disengaged. The operating system must be switched off!
- Pay attention to the width and height of the crane in the transport position. The crane must stay within the width of the truck.
- Make sure the stowed crane and its accessories cannot fall, hit bridges, tunnels, other vehicles etc.
- Pay attention to overhead power lines! Make sure that no part of the crane ever comes in contact with overhead power lines.

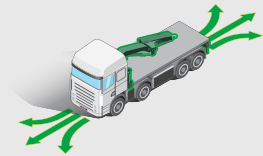

NOTE

- For further instructions, refer to the vehicle's manual(s).
- Make sure that you always obey local traffic rules when driving with a crane.

3.5.4. Use of lifting equipment



DANGER

- Only use lifting accessories (grapple, rotator) that are correct for your crane. Contact an authorised service workshop.
- Never attempt to install add-on lifting accessories yourself!
- Add-on lifting accessories may only be installed by an authorised service workshop.
- When using lifting accessories, follow the instructions supplied with the equipment!
- Watch out for hazards!
- Never try to adjust lifting accessories when you are working on the crane!

After the lifting accessories have been fitted, verify that they are securely fixed. Only after this, you may use your crane.

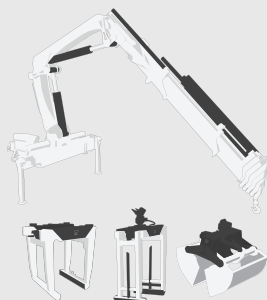

WARNING

Always insert the locking pins in the shaft for all the attachments on the tip of the crane (hook, other add-on equipments...).

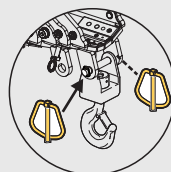

WARNING

If you attach/detach equipment to/from the tip of the crane and the boom system is not in horizontal position, stay away to avoid getting caught between the boom extensions as it is normal that they can move towards each other.



WARNING

- Clean the couplings, when connecting and disconnecting lifting accessories. Dirt can damage the hydraulic system.
- Be careful that your fingers do not get trapped.

3.5.5. Use of demountable cranes



DANGER

- Make sure that there are no unauthorised persons in the immediate vicinity of the crane. When mounting/demounting the crane on/from the vehicle, people can suffer fatal crushing injuries!
- After setting up, verify that the crane is properly locked!



WARNING

Be careful when mounting/demounting the crane on/from the vehicle as rough handling can seriously damage the crane or the vehicle.

3.5.6. Ending crane operation



DANGER

Always end crane operation as follows:

- After use, always place the crane in the transport position!
- Withdraw the stabiliser legs and stabiliser extensions.
- Check that the locking mechanisms are properly locked.
- Switch off the operating system.
- Disengage the PTO or power supply after work.
- If you drive with the PTO or power supply engaged, this will cause serious damage to the PTO/gearbox combination.
- Only after doing the above, you can drive the vehicle away.

4. The Operating system

4.1. Components of the operating system

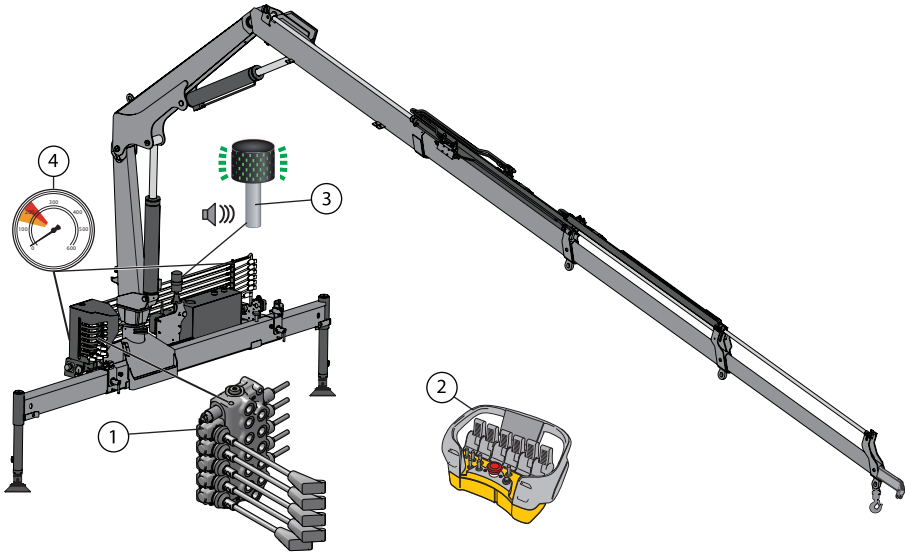

| | |
|----------------------------------|---|
| (1) Main control valve | (3) Warning lamp [option] for remote controlled cranes. |
| (2) SCANRECO controller [option] | (4) Pressure gauge |

4.2. Description of the operating system

| Crane version | Control valve | Operating system | Controller |
|---------------|---------------|---|-------------------|
| EFFER 35 | Walvoil | Two pressure gauges for overload monitoring | SCANRECO [option] |



DANGER

Never try to repair the operating system yourself. Repairs may only be made by an authorised service workshop!

4.3. Emergency stop buttons

Crane with manual control station

Cranes with manual control stations have 2 emergency stop buttons on each side of the crane.

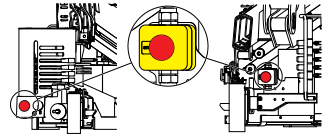

Crane with controller (option)

Cranes with remote control have 2 emergency stop buttons, 1 close to the control station and 1 on the controller.

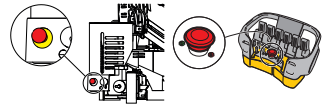

4.4. Standard symbols and functions of the crane

These symbols can be shown:

- On the control valve levers.
- On the controller (If delivered).



NOTE

For normal operation, you will use the main control valve levers or the controller [option]. You can read about the symbols displayed on it in the dedicated section of this operator's manual.

By default, the symbol on the main control valve levers or the controller [option] corresponds to the positive movement of the levers. To operate the opposite movement of that symbol, move the lever in the opposite direction.

Always operate the lever according to the function on the symbol sign.

Basic crane symbols and functions

| SYMBOLS | | FUNCTIONS | SYMBOLS | | FUNCTIONS |
|---------|--|------------|---------|--|----------------------|
| | | Slewing | | | Second boom |
| | | First boom | | | Hydraulic extensions |

Accessories symbols and functions (if delivered)

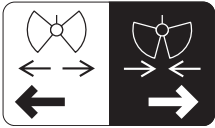
| SYMBOLS | FUNCTIONS |
|---|-----------|
|  | Rotator |
|  | Grapple |

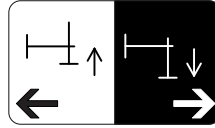
| SYMBOLS | FUNCTIONS |
|---|-----------------|
|  | Stabiliser legs |

4.5. Main control valve

4.5.1. Crane with manual control station

The crane has two control stations, one on each side of the crane. Operate the crane and stabiliser legs from one of the two control stations.







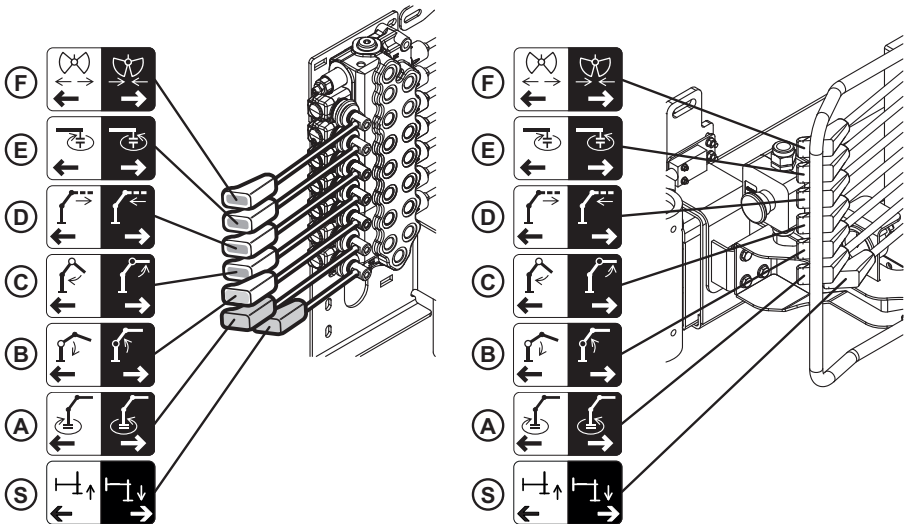



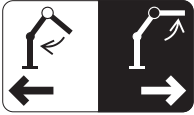

DANGER

Do not operate the crane from two control stations at the same time. Unexpected movements could occur.

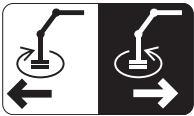

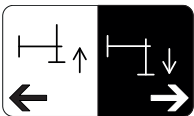
| Lever | Component | Lever position | Movement |
|-------|----------------------|----------------|---|
| (F) | Grapple | | Open Close |
| (E) | Rotator | | Clockwise rotation counterclockwise rotation |
| (D) | Hydraulic extensions | | Extend Retract |

| | | | | |
|-----|----------------|---|--|--|
| (C) | 2nd boom |  |   | <p>Down</p> <p>Up</p> |
| (B) | 1st boom |  |   | <p>Down</p> <p>Up</p> |
| (A) | Slew |  |   | <p>Clockwise slewing</p> <p>counterclockwise slewing</p> |
| (S) | Stabiliser leg |  |   | <p>Up</p> <p>Down</p> |

4.5.2. Crane with remote control [option]

A remote-controlled crane cannot be operated from the main control valve, but only through a controller.

The stabiliser legs can be operated by the main control valve from both sides of the crane. Stabilisers extension can be operated only manually.

The main control valve becomes the control station only for emergency operation (refer to the section “Emergency operation” for more information).

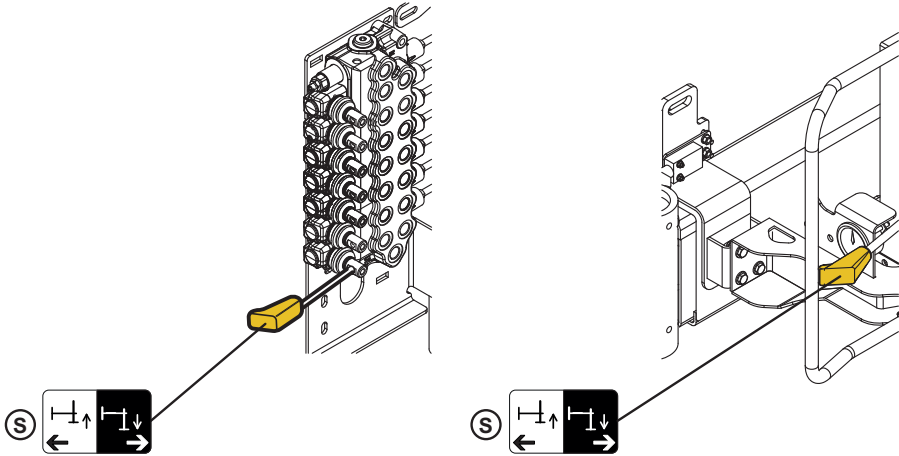

| Lever | Component | Lever position | Movement |
|-------|----------------|----------------|---------------------------|
| (S) | Stabiliser leg | | <p>← Up</p> <p>→ Down</p> |

4.6. SCANRECO controller [option]

The SCANRECO controller system consists of:

- a controller unit with buttons/selectors and levers
- a receiver
- an emergency cable
- two batteries
- a battery charger and its accessories
- a belt/shoulder strap

The controller normally communicates with the crane through the receiver via radio, but it can also be used with a cable (when the batteries are discharged or when the use of radio frequencies is forbidden).

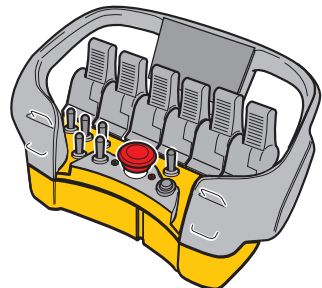

**CAUTION**

- Use the support strap for safe operation.
- Never leave the remote unattended.
- Disconnect it and store it in a safe place when not in use.

**NOTE**

- For safety reasons, and to minimise battery consumption, the controller automatically turns off after 5 minutes of inactivity.
- To have a correct communication between the controller and the crane system, the controller cannot be more than 100 meters away from the crane without large obstacles in between.

4.6.1. Buttons, selectors and LEDs

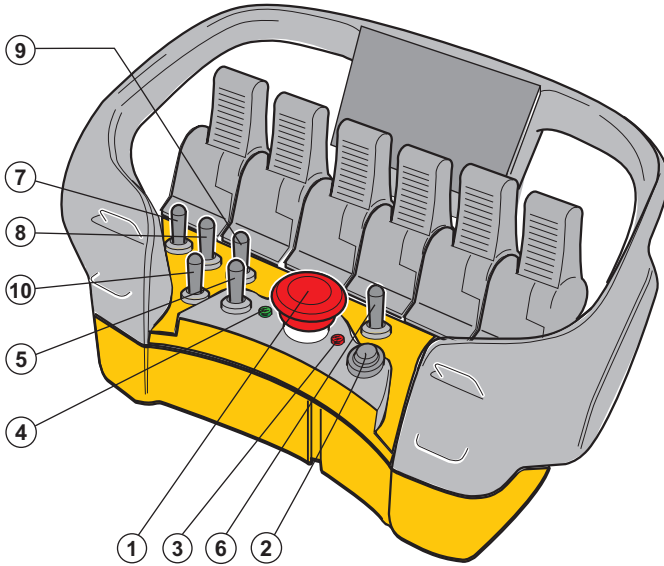

| | | | |
|--|---|--|-------------------------------|
| <p>(1) Emergency stop button</p> | <p>(4) LED for radio connection:</p> <ul style="list-style-type: none"> • Flashing: the transmission is bad. | <p>(7) Auto Rpm ON/OFF</p> | <p>(10) Not in use</p> |
| <p>(2) Button:</p> <ul style="list-style-type: none"> • Activate the controller. • Horn | <p>(5) Speed adjustment:</p> <ul style="list-style-type: none"> • 5 positions based on preset values. | <p>(8) Truck engine ON-OFF</p> <p>Truck engine ON</p> <p>Truck engine OFF</p> | |
| <p>(3) LED for battery status:</p> <ul style="list-style-type: none"> • On: remote on and the battery is charged. • Flashing: the battery must be replaced. | <p>(6) Operation selector mode:</p> <ul style="list-style-type: none"> • Left: CRANE mode (CRANE) • Right: STABILISER SYSTEM mode (STAB) | <p>(9) Truck engine Rpm</p> <p>Rpm increase</p> <p>Rpm decrease</p> | |

Locking the controller:

Push the emergency button.

Unlocking the controller:

1. Release the emergency button.
2. Push and hold for at least two seconds the button (2) to activate the controller.













4.6.2. Standard functions and symbols

Standard functions and symbols of the crane



NOTE

The function corresponding to each lever depends on the configuration of the specific crane. The following tables are examples.

| Lever | Component | Lever position | | Movement |
|-------|----------------------|---|---|----------------------------------|
| (A) | Slewing |  | 1 | clockwise slewing |
| | |  | 2 | counterclockwise slewing |
| (B) | 1st boom |  | 1 | up (unfolding) |
| | |  | 2 | down (folding) |
| (C) | 2nd boom |  | 1 | up (unfolding) |
| | |  | 2 | down (folding) |
| (D) | Hydraulic extensions |  | 1 | out (extracting boom extensions) |
| | |  | 2 | in (retracting boom extensions) |
| (E) | Rotator [option] |  | 1 | clockwise rotation |
| | |  | 2 | counterclockwise rotation |
| (F) | Grapple [option] |  | 1 | grapple (opening/closing) |
| | |  | 2 | grapple (opening/closing) |

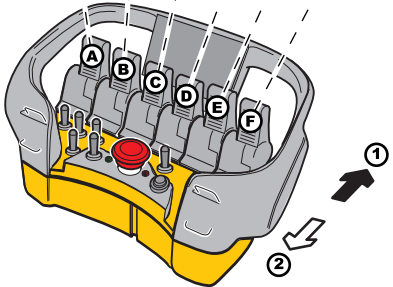

4.6.3. Battery and battery charger

Battery

We recommend that you have a spare controller battery, already charged, to avoid machine downtime. A fully charged battery provides approximately 8 hours of use (at 25°C, 77°F) and the voltage level is approximately 7.2 V. When the battery is about to be out of power an indicator LED (3) on the controller flashes and you hear a beep for three times. Replace the battery within 5 minutes.

Battery charger

Connect the battery charger in a protected environment, preferably in the cab.

1. Connect the battery charger to the power supply using the cable provided.
2. The red LED (1) turns on.
3. Place the battery in the charger.
4. The green LED (2) flashes slowly during recharging and has a steady light when the battery is fully charged.

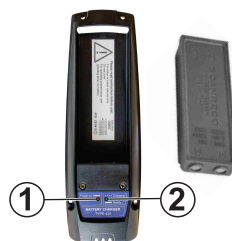

NOTE

The charging time is approximately 3 hours.

Charging the battery in the controller with the cable

Operating ambient temperature for charging: Battery = 0°C to + 45°C (32°F to 113°F).

When the serial cable is connected, the battery inside the controller will automatically recharge.

1. Push the emergency stop button on the crane and on the controller.
2. Insert the battery.
3. Connect the serial cable to the receiver.
4. Release the emergency stop button located on the crane and on the controller. The controller is ready to use, turn it on if needed.



NOTE

The charging time is approximately 12-14 hours.



CAUTION

- Charge the battery when it is out of power.
- Do not leave the battery without charging it for more than six months.
- Keep the battery and its contacts clean.

**NOTE**

A charged battery is a concentrated energy source. Never store a charged battery in a toolbox or similar where there is a risk of a short circuit because of contact with metal components. Refer to local regulations to discard used batteries.

4.7. Warning lamp and audible warning device [option]

In remote-controlled cranes the green lamp lights to alert that the crane is in operation mode. The audible warning device is activated by the remote control

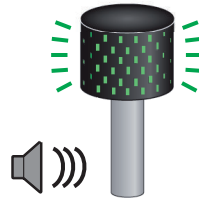

4.8. Pressure gauge

During the operation the gauge detects the pressure of 1st boom cylinder.

When the load lifted is close to the maximum, the indicator of the pressure gauge moves in the orange area (1) (pre-alarm zone).

When the maximum load is reached, the indicator of the pressure gauge moves in the red area (2) (alarm zone).

Always during the operation keep under control the pressure gauge to avoid overload. You, as the operator, are responsible to make sure that do not lift more than the maximum load.

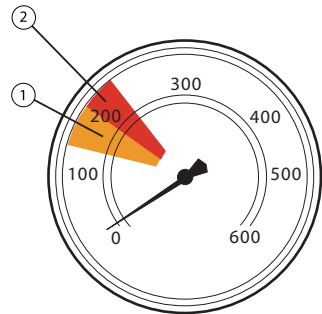
**DANGER**

Do not extend the booms and extensions when the indicator is in the red area. The load could uncontrolled descend and cause the tipping of the truck.

**DANGER**

Never try to repair the operating system yourself. Repairs may only be made by an authorised service workshop!

5. Starting crane operation

5.1. Starting operations

Put the vehicle on a flat, firm, and stable surface.



IMPORTANT

To avoid sudden movements of the vehicle and damages to the stabiliser system, the vehicle must be completely levelled in any direction ($\alpha=0^\circ$) with the crane in transport position and the boom system folded before starting any operation.

To determine the inclination of the truck, check the spirit level on the crane. When the bubble is in the middle of the gauge, the crane is in horizontal position.

The vehicle inclination (α) during crane operation must **not be more than 3°** when working with the boom system below 30° .

The vehicle inclination (α) during crane operation must **not be between 0° and 1°** when working with the boom system above 30° .

If these values are exceeded, unintentional crane movements can occur.

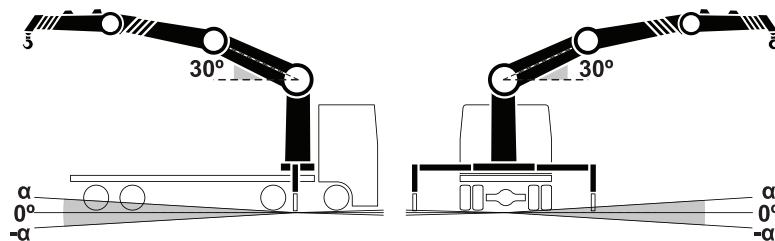
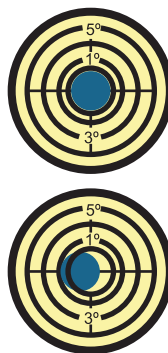

CAUTION

- Remember to operate the crane into and out of the transport position with the vehicle completely levelled.
- Activate the parking brake and place chocks under the wheels to prevent vehicle movement.

Engage the PTO

1. Activate the parking brake and place chocks under the wheels to prevent vehicle movement.
2. Engage the PTO (Power Take Off) and bring the vehicle engine to the correct rpm.



NOTE

- Rpm too high: the oil in the hydraulic system might overheat.
- Rpm too low: during crane operation, the vehicle engine could stall.
- The maximum rpm may depend upon a governor on your PTO combination.



CAUTION

Close the driver's cab to prevent access to unauthorised persons.

Start the operation system

Make sure that all the levers are in neutral position before you start the operating system.

Pull out all the emergency stop buttons by turning them clockwise.

Start the controller [option]

Fasten the controller to a waist belt, or shoulder-/neck strap, in the most comfortable operating position.

1. To activate the controller, pull out the emergency stop button by turning it clockwise.
2. Push button **(1)** to activate the controller
The LED **(3)** becomes steady when the controller is active and LED **(2)** flashing green indicates a correct radio communication between the transmitter and the receiver.
3. Push button **(1)** again.

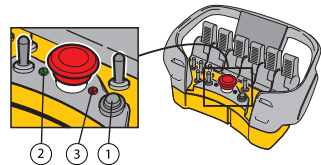

TIP

If the controller is ON, but the crane does not operate, check that the Mode switch (1) on the receiver is in the REMOTE position

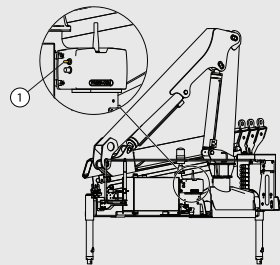

5.2. Set the stabiliser system

To operate the crane, all the stabiliser extensions and legs must be fully extended and set to the ground without lifting the wheels from the ground.

The crane operates with the same lifting capacity for the whole working sector.

5.2.1. Stabiliser system and ground conditions

Always:

- Make sure that the ground can support the load that the stabiliser leg imposes on the ground. (*)
- Make sure that the ground is not undermined.
- If the ground is not sufficiently compact and resistant, add an extra support plate under the stabiliser legs.
- Use the extra support plates that are large and firm enough for your crane model.

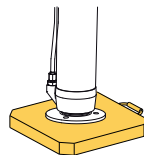

The maximum permitted ground inclination under the stabiliser leg plate is 5°.



(*) **The maximum load that the stabiliser leg can apply to the ground is:**

| Crane model | Max. reaction (R _{max}) [daN] | Pressure (*1) [MPa] | Plate area [m ²] | Standard plate dimensions (*2) (*3) [m] |
|-------------|---|---------------------------|---------------------------------|---|
| EFFER 35 | 2804 | 1.70 | Disk: 0.0165 | NOT NECESSARY |

(*1) Pressure on the ground surface.

(*2) Plate dimensions according to the standard EN 12999-2011 (P<4 MPa). Standard supply.

(*3) The same plates for crane stabiliser legs must be provided for auxiliary stabiliser legs.



NOTE

- The load plate shows the maximum force that the stabiliser legs can apply to the ground.

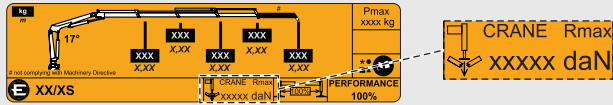

- There is a plate on the auxiliary stabiliser legs which shows the maximum force that the stabiliser legs can apply to the ground.

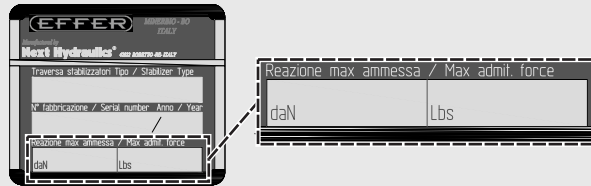

DANGER



Verify that the extra support plates do not bend or sink into the ground.

Do not lower the stabiliser legs on the edge of an embankment, soft ground, hollows, etc... Lower the stabiliser legs only onto a flat, firm, and stable surface.

5.2.2. Activate the stabiliser system

- Move to the side of the crane where you want to start the operation.
- Make sure that you have full view of the stabiliser system.



WARNING

- You must always have a clear view of the stabiliser system when operating.

- Activate the related lever.

5.2.3. Extend the stabiliser extensions



WARNING

Do not extend/retract the extensions by holding the hydraulic hose. Risk of damage or personal injuries.

1. **Only for remote-controlled cranes:** Turn the CRANE/STAB selector on the controller [option] to STAB
2. Turn the locking device (1) 180° pointing upwards
3. Pull the locking device (2) free from the pin (3)
4. Manually extend the stabiliser extension about 20 cm
5. Turn the locking device (1) 180° pointing downwards
6. Manually extend the stabiliser extension until you see the coloured strip and the locking device (1) lock the extension.
7. Make sure that the stabiliser extension are fully extended and locked.

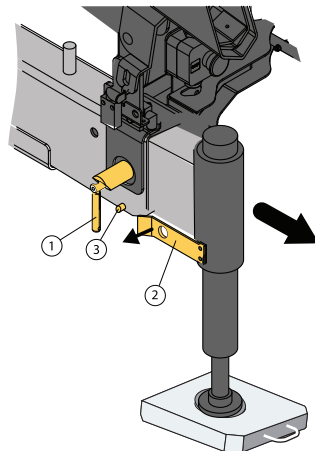

Repeat the instructions for the stabiliser extension(s) on the other side of the vehicle.

The procedure of setting the auxiliary [option] stabiliser extensions differs depending on the type of stabiliser extensions.

5.2.4. Set the stabiliser legs



WARNING

Take care not to lower the stabiliser leg onto your foot.



DANGER

Always ensure that the stabiliser legs and stabiliser extensions are in working position and securely locked.



NOTE

At the end of the operation, do a check of the levelling of the vehicle with the spirit level. If necessary, adjust the stabiliser system.

Put the extra support plates

- Put the extra support plates under the stabiliser leg plates (if necessary).

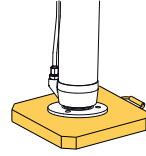

DANGER

Do a check that the support plates do not bend or sink into the ground!

Stabiliser legs

1. Make sure that the stabiliser extensions are fully extended and locked.
2. Move the lever (A) to the horizontal position.
3. Put the extra support plate (1) onto the ground (if necessary).
4. Extend the stabiliser leg until it is set to the ground.
5. Turn the lever (A) vertically.

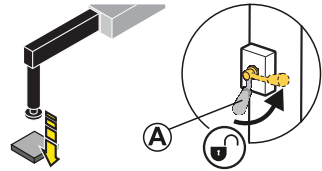

Repeat the instructions for the stabiliser leg(s) on the other side of the vehicle.

The procedure of setting the auxiliary [option] stabiliser legs differs depending on the type of stabiliser legs.

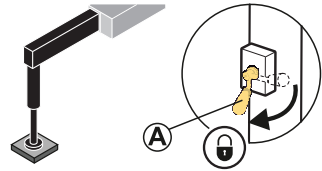

5.3. Operate the boom system out of transport position



WARNING

- A crane with add-on equipment can differ from the operations described in this section. For this reason, study the operating instructions for any add-on equipment carefully.
- Always ensure that the stabiliser extensions and legs are in working position and securely locked before operating the boom system out of parking position.
- We recommend that you do these operations slowly or use the option for reduced speed.



DANGER

Always operate a manually controlled crane from the position shown in the image!



DANGER

- With remote-controlled cranes, stay in a safe area while the boom system is moving.



5.3.1. How to operate the boom system

1. Remove the safety pin that locks the 1st boom.
2. **Only for remote-controlled cranes:** Turn to selector CRANE/STAB to CRANE on the controller (option)
3. Operate the 2nd boom against the 1st boom (1) to raise it from its rest position on the column.
4. Retract the extensions (2).



CAUTION

Do these operations slowly to prevent damage to the crane.

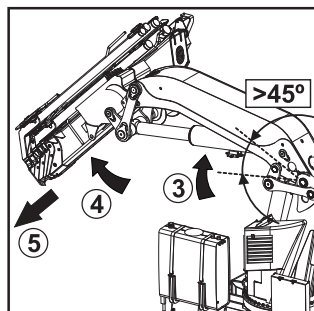
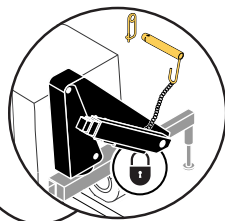
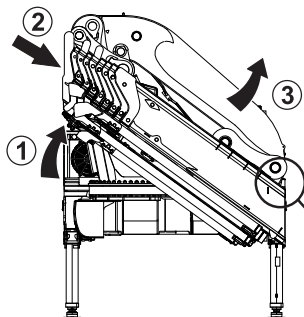

5. Raise the 1st boom (3) of about 45°.
6. Raise the 2nd boom (4).
7. Slew the crane to the working position.
8. If needed, extend the crane boom extensions (5).

6. During operation



CAUTION

When operating several functions simultaneously and releasing one or more of those functions. There will be an uncontrolled increase in the speed of the crane movements. Proceed with caution.

6.1. Hook assembly

1. Assemble the hook (1) and the bow shackle (2)
2. Attach the bow shackle (2) to the hook attachment using the threaded pin (3)
3. Screw the nut (4) up to the stop
4. Install the cotter pin (5) to lock the assembly.

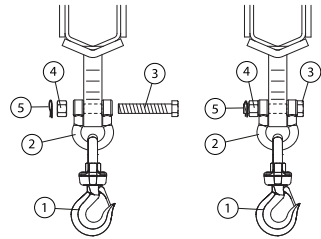

DANGER

Care must be taken when handling loads in the high lifting area, so the load/tool does not come into contact with the boom system.

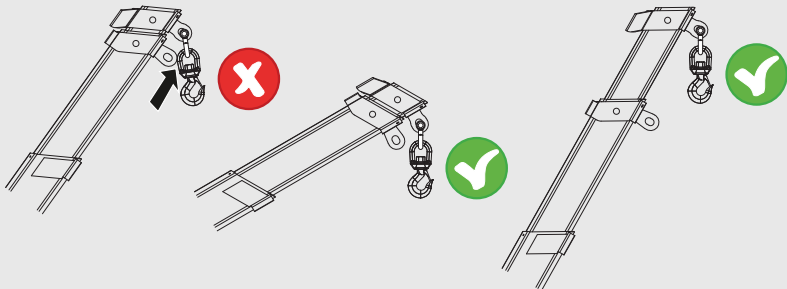

6.2. Controlling the crane speed with the controller SCANRECO [option]

When you turn the speed selector, all levers must be in neutral position.



NOTE

The crane speed always depends on the crane functions you are using and how many crane functions you operate at the same time.

- To activate the snail feature and reduce the speed, turn the selector (1) to the snail (L).

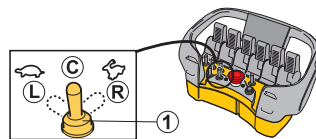

NOTE

Move the selector (1) to the left for a maximum of five times to adjust the crane's reduced speed. These five reductions are from 100% to 60%, 50%, 40%, 30% and 20%.

| Green LED (3) | Indication |
|-----------------------------|-------------------------|
| Not lit | 0 to 100% reduced speed |
| 1 blink every three seconds | 0 to 60% speed |
| 2 blink every three seconds | 0 to 50% speed |
| 3 blink every three seconds | 0 to 40% speed |
| 4 blink every three seconds | 0 to 30% speed |
| 5 blink every three seconds | 0 to 20% speed |



WARNING

- If you turn the selector to the (R) position, the crane returns to the reduced speed (100%).
- If you push the emergency stop button on the controller, the last speed selected will be active when you start the controller again.

- To deactivate both features, turn the selector (1) to centre position (C).

6.3. Pressure gauge

Always during the operation keep under control the pressure gauge to avoid overload.

- (1) pre-alarm zone
- (2) alarm zone

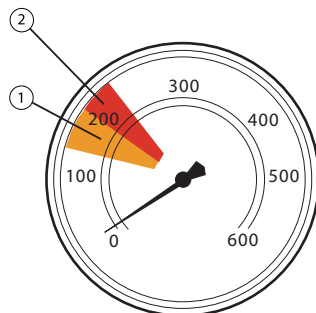

6.4. Manual extensions [if installed]

Operation with manual extensions:

Use the manual extensions only when you need the longest outreach, otherwise remove them.



DANGER

- Do not stand in front of moving parts. They may eventually move and cause injuries.
- Before driving with the crane, make sure that you fully retract the manual extension and lock them correctly. Make sure that they stay within the width of the truck.



CAUTION

To prevent a safety risk and to get the maximum performance on the crane:

- You must always attach the load to the last extension.
- Never attach the load to an extension which has other extensions included inside it.

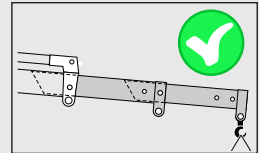
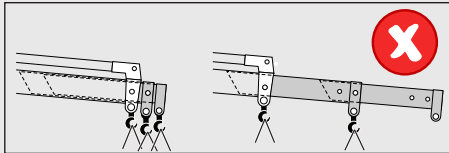

How to assemble and disassemble the manual extensions:

Select the correct lifting device according to the weight of the extension.

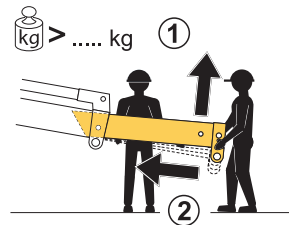
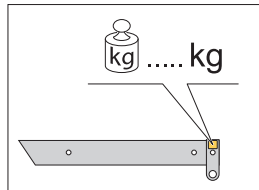
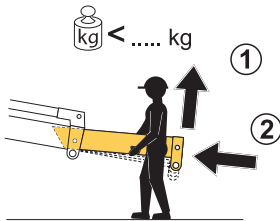

Assembly procedure:

1. Operate the hydraulic extension a small distance below the horizontal.
2. Slightly incline the manual extension (1) and insert it (2).
3. Align the holes in both extensions and lock the extensions with the locking pins and the locking shafts (A).
4. Repeat the same operation if you have more than one manual extension.

Dismantling procedure:

1. Operate the hydraulic extension a small distance below the horizontal.
2. Remove the locking pins and the locking shafts **(A)**.
3. Raise the manual extension to avoid the stop **(B)**, if installed, and slide it out carefully.
4. Repeat the same operation if you have more than one manual extension.

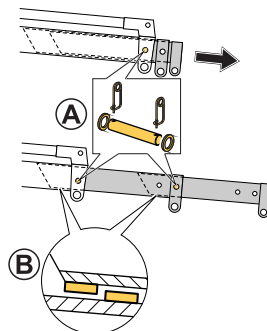
CAUTION

- Make sure that the manual extensions are always properly locked by the locking pins and the locking shafts **(A)**.
- Do these operations carefully to avoid damaging the stop **(B)**, if installed.
- If there is no stop **(B)**, you must extract the extension carefully because it could fall suddenly when you take it out.

To extend the manual extensions:

1. Put the boom system as close as possible to the horizontal position, but low enough to reach the extension by hand or with the lifting device.
2. Push the stop emergency button to stop the crane.
3. Remove the locking pins and the locking shafts **(A)**.
4. Fully extend the manual extension by hand.
5. Secure the manual extension with the locking pins and the locking shafts **(A)**.

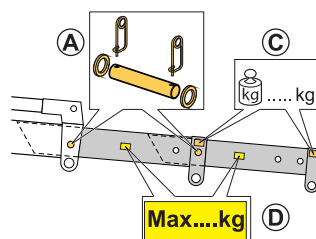
DANGER

- Make sure that the locking devices are properly locked.
- Each manual extension is marked with its own weight **(C)**.
- Each manual extension has a sign **(D)** for the maximum load that can be handled.
- Do not lift loads heavier than the values stated on the sign **(D)**.

To lift heavier loads than specified on the sign **(D)**, move the hook to the nearest hydraulic extension and refer to the load plate on the crane.

To retract the manual extensions:

1. Put the boom system as close as possible to the horizontal position, but low enough to reach the extension by hand or with the lifting device.
2. Push the stop emergency button to stop the crane.
3. Remove the locking pins and the locking shafts **(A)**.
4. Fully retract the manual extension by hand.
5. Secure the manual extension by locking the locking pins and the locking shafts **(A)**.

DANGER

Make sure that the locking devices are properly locked.

6.5. Hydraulic couplings [option]

Hydraulic couplings allow a faster connection and disconnection of each hydraulic line.

WARNING

- Push the emergency stop button and switch off the PTO before connecting or disconnecting the connectors.
- Keep the hydraulic protection caps in good condition.

To connect the hydraulic couplings you must:

1. Push the emergency stop button.
2. Disengage the PTO.
3. Connect the respective hydraulic couplings taking care with the corresponding identification.

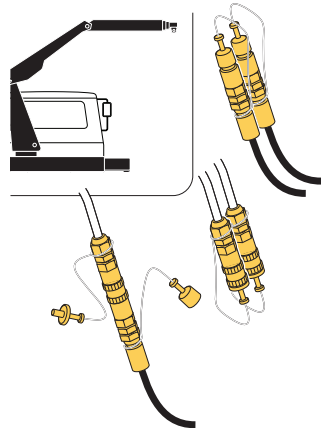
NOTE

To prevent damage, do not change the hydraulic couplings position.

4. Reconnect the PTO and switch on the system, if needed.
5. Do a functional test of all movements of the accessories to verify that there are no mistakes in the connections.

To disconnect the hydraulic couplings you must:

1. Push the emergency stop button.
2. Disengage the PTO.
3. Disconnect the hydraulic couplings, and protect them with protective caps.
4. Reconnect the PTO and switch on the system, if needed.
5. Operate the crane to verify that all functions work correctly.

7. Ending crane operation

7.1. Operate the boom system into transport position



WARNING

- A crane with add-on equipment can differ from the operations described in this section.
- For this reason, study the operating instructions for any add-on equipment carefully.



DANGER

During folding of the boom system, always operate a manually controlled crane from the position indicated in the figure.



DANGER

- With remote controlled cranes, stay in a safety area while the boom system is moving.
- We recommend that you do these operations slowly or use the option for reduced speed.

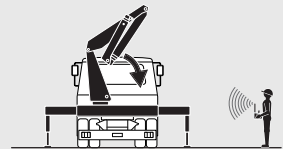

7.1.1. How to operate the boom system

1. Retract the extensions completely (1).



CAUTION

The extensions might not retract in sequence.

2. Raise the 1st boom (2) until the boom reach about 45°.
3. Slew the crane to the parking position. Verify that the arrows signs (A) on the column and on the base are aligned.
4. Operate the 2nd boom against the 1st boom (3) .

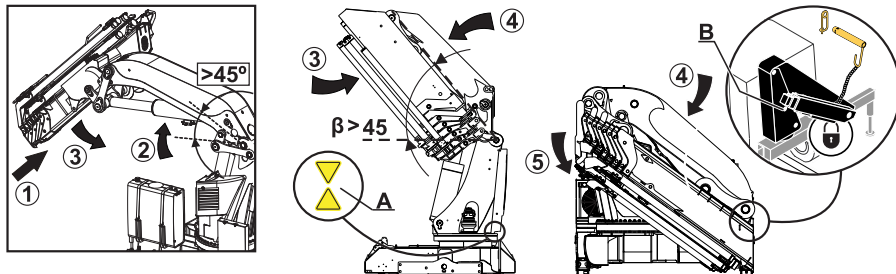

5. Lower the 1st boom completely (4) to the parking support of the base.



CAUTION

Do these operations slowly not to cause damage to the parking support.

6. Lightly operate the 2nd boom (5) against the parking support (B) of the column until it has contact with the support.



CAUTION

Take care not to cause damage to the 2nd boom and the support during these operations.

Do not apply too much force on the parking support.

7. Insert the safety pin that locks the 1st boom.

8. Fold the hook.

7.2. Placing the stabiliser system in the transport position



WARNING

- Do not put your foot on the support plate.
- Risk of crushing injuries.
- Always keep hands away from moving parts during operation.



WARNING

Do not operate any stabiliser leg up if you still have load on the crane.

The procedure of operating the auxiliary [option] stabiliser legs differs depending on the type of stabiliser leg. Repeat the instructions for the stabiliser extension and leg on the other side of the vehicle.



DANGER

Always ensure that the stabiliser legs and the stabiliser extensions are in transport position and securely locked before moving the vehicle.

Stabiliser legs

1. **Only for remote-controlled cranes:** Turn to selector CRANE/STAB to STAB on the controller (option)
2. Turn the lever (A) horizontally.
3. Fully retract the stabiliser leg
4. Move the lever (A) to the vertical position
5. Remove the extra support plate.

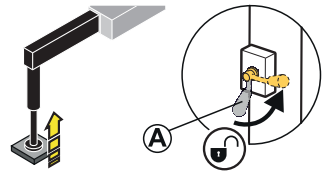

Repeat the instructions for the stabiliser leg(s) on the other side of the vehicle.

The procedure of closing the auxiliary [option] stabiliser legs differs depending on the type of stabiliser legs.

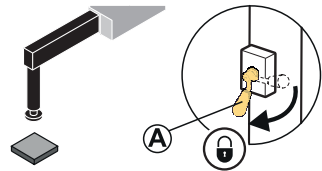

WARNING

Risk of crushing injuries.

Always keep hands away from moving parts during operation.

Retract the stabiliser extensions



WARNING

Do not extend/retract the extensions by holding the hydraulic hose. Risk of damage or personal injuries.

1. Turn the locking device (1) 180° pointing upwards
2. Manually retract the stabiliser extension about 20 cm
3. Turn the locking device (1) 180° pointing downwards
4. Retract the stabiliser extension completely
5. Make sure the locking device (1) lock the extension
6. Make sure the pin (3) goes into the hole on the locking device (2)

Repeat the instructions for the stabiliser extension(s) on the other side of the vehicle.

The procedure of setting the auxiliary [option] stabiliser extensions differs depending on the type of stabiliser extensions.

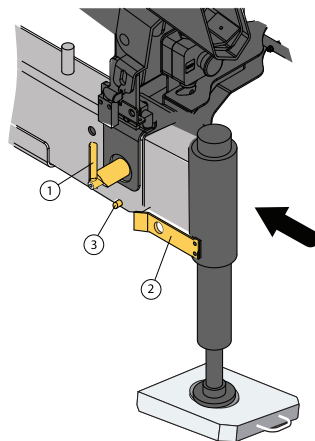

7.3. Switching off the system

1. Push the emergency stop button on the crane or on the controller [option].
2. Disengage the PTO.

7.4. Emergency operation

7.4.1. Crane movements in an emergency



WARNING

- The use of any emergency operation is under your direct responsibility as operator of the crane.
- You must be qualified and correctly trained in the emergency operation to use the manual commands unit. Pay careful attention when operating from the operator station (crushing, falling, etc...) and watch out for hidden hazards (low visibility, narrow spaces, etc...).
- Always operate the crane with caution and at reduced speed.
- It is strictly forbidden to use any emergency operation as normal operation (for example lifting a load).
- Always go to/contact an authorised service workshop when a security seal has been broken.

EMERGENCY operation of remote controlled crane



DANGER

Operating the crane in this way is HIGHLY DANGEROUS because during emergency operation you may be forced to operate in conditions of poor visibility of the operating area or very close to the crane boom.

1. Push the emergency stop button on the controller
2. Move the mode switch (1) on the receiver to the **MANUAL** position
3. Install all the emergency levers supplied on the main control valve. Refer to the chapter **Crane with manual control station**
4. Operate only one function at a time.
5. Go to an authorised service workshop to set the crane again to the normal operation.

They have the same functionality as the crane stabiliser system. Refer to section [A] in this chapter for more information.

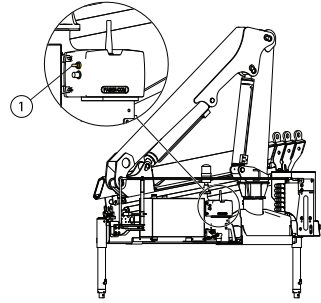

7.5. Transport Warning

The system detects that the stabilisers and crane boom system are in transport position before the operator starts driving, and also during the transport.

A device installed in the dashboard of the truck TRI (Transport Reporting Interface) warns the driver with a luminous and acoustic signal of an incorrect position during the transport:

- Red warning light (1) on: the height of the crane exceeds a set maximum value.
- Red warning light (2) on: at least one of the stabiliser extensions is not in transport position.
- Buzzer OFF button (3).
- Green warning light (4) on and the rest of the lights off: the crane and stabiliser system is in transport position and the vehicle is ready to move.
- The buzzer (5) sounds if one or both warning lights (1) and (2) are active.

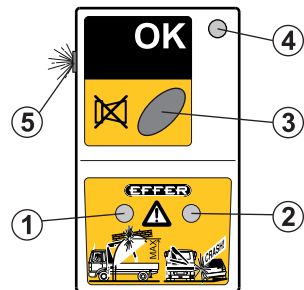
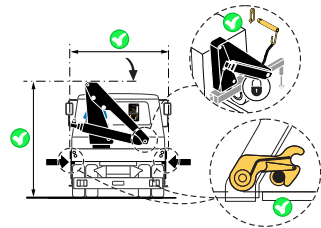

NOTE

- During the crane operation, the red lights are lit and the buzzer is active. You are able to turn off the buzzer by pushing the button (3).
- If you are driving the vehicle and the height of the crane or the stabiliser extensions change from the transport position, the system gives a warning in the cab.

**CAUTION**

- Do not move the vehicle if you see or hear the warning on the TRI.
- Stop the vehicle immediately if the visual alarm / sound is active while driving:
 1. Switch on the system.
 2. Operate the boom system and the stabiliser extensions to their transport position.
 3. Make sure that the locking devices are in good conditions and in place.
 4. Switch on the system.
 5. If you can still see/hear the warning, secure the crane and the stabiliser system positions and go immediately to an authorised service workshop.

**DANGER**

- After use, always put the crane into the transport position!
- When you have to park the boom system on the truck body (if designed by the installer), secure the boom system and the lifting accessories to prevent any unintentional movement of the crane and the lifting accessories.

8. Maintenance and Service

8.1. Service

No welding/drilling work on the crane



DANGER

- Do not do any welding work on the crane. Welding work on the crane may only be carried out by an authorised service workshop.
- Do not drill into the crane yourself. Drilling work on the crane may only be carried out by an authorised service workshop.
- Never try to reinstall the crane. Only an authorised Installer may reinstall the crane.



Disconnecting hydraulic lines for accessories

You can disconnect a hydraulic line or a hose only for specific operator's tasks (for example, disconnecting accessories).

1. Make sure that the cylinders are not at the end of stroke and minimise as much as possible the forces acting on them.
2. Switch off the system.
3. Disengage the PTO.
4. Make sure that you wear the correct personal protective equipment.
5. Slowly loosen all connectors.

Leakages



DANGER

- STAY AWAY from oil leaks in the hydraulic system! Oil in the hydraulic system is under high pressure, can spill, be very hot and cause you injury.
- Do not replace any hydraulic hoses or lines yourself.

Deal with an oil leak as follows:

1. Rest the crane on the floor or on the truck platform.
2. Switch off the control system.
3. Disengage the PTO.

Leaking coupling:

- a. Do not tighten the coupling with a spanner. You could damage the O-ring of the coupling.
- b. Contact an authorised service workshop.

Small leak on a line or hose:

- a. Determine if you can still park the crane.
- b. If you can, park the crane and go to an authorised service workshop.
- c. If you cannot, contact an authorised service workshop.

8.2. Warranty

The Seller only provides Warranty if the conditions specified in the "Service and Warranty Manual" are fulfilled.

Refer to the Service and Warranty Manual of your Product.

8.3. Follow the maintenance instructions!

Take the crane to an authorised service workshop for inspection and maintenance. Maintain lifting accessories according to the supplier's instructions.

**WARNING**

- Make sure that faults in the crane are corrected immediately!
- Never correct faults yourself that may only be corrected by an authorised service workshop.
- Carry out yourself only the service and maintenance work you have the requisite knowledge and experience for. Maintenance must be performed by qualified personnel.
- Always use personal protection devices and other safety means during the maintenance work in compliance with the regulations of the country in which you use the crane.
- All personnel must understand and comply with all warning and instructional decals attached to the body, crane and truck controls.
- Mark out the working area and make sure that there are no unauthorised persons inside.
- NEVER walk or stand under a crane or a suspended part. People may suffer fatal crushing injuries!
- When working on any part of the crane, put the "Out of Service" tags displayed clearly and wherever possible on the vehicle, and remove the ignition keys to prevent accidental operation.

**NOTE**

- Make sure that you have read the complete manual before starting the preventive maintenance. It provides detailed information about the maintenance process.
- Make sure that the manual and other documentation are in good condition, near the machine and available for anyone who needs it.

Maintenance intervals:

- Carried out by the **operator: daily and monthly inspection.**
- Carried out by an authorised service workshop:
 - **1st service:** to be made after 50 hours or 2 months of use.
 - **Regular service:** to be made when one of these conditions are met:
 - 1,000 hours of use
 - 365 days



NOTE

These maintenance intervals could be needed more frequently if the use of the crane is in special conditions (high amount of cycles, heavy loads, etc...) and/or hard environmental conditions (deserts, mines, etc...). Please, contact your Effer representative.



NOTE

Refer to the "Service and warranty manual" to know the actions performed by the authorised service workshop.

Long storage of the crane

If you need to store your crane for a month or longer, do this first:

1. Clean it according to the instructions in the section "Cleaning" of this manual.
2. Lubricate it according to the lubrication schedule of this manual.
3. Put the crane into transport position and disconnect the power from the vehicle battery.
4. Put grease on the exposed piston rod(s) and the external seals of the hydraulic cylinders.
5. Put a plastic cover on the crane.
6. Protect it from rain, sun and dirt as much as possible.

Cleaning

Clean your crane and accessories regularly, but:

- Always set the power off before you start.
- Do not use aggressive cleaning agents.
- If you use a high pressure water jet, make sure that:
 - Temperature of the cleaning water is between 50°C-60°C.
 - Maximum working pressure is 150 bar.
 - Minimum distance between the nozzle and the surface to clean is 80 cm.

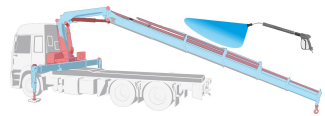

CAUTION

Never use a high pressure water jet on electronic parts, plastic components, signs, bearings, control valves, cylinders or the oil tank. Only the cranes surface may be cleaned with a high-pressure jet cleaner.

**NOTE**

Always lubricate after cleaning the crane.

**WARNING**

Keep the devices to go into the control station (handles, supports, platforms...) clean from oil, grease and dirt to prevent slipping and falling.

8.3.1. Daily inspection

**NOTE**

Refer to the daily inspection checklist at the end of this manual to photocopy.

Presence of signs and symbols

- See chapter "Safety precautions and warnings" under section "Signs on the crane". Make sure that all the signs shown in section "Signs on the crane" are in position and in good condition.
- Make sure that all the symbols on your crane are in good condition.

Locking devices

- Make sure that all locking devices are undamaged and working properly.
- Make sure that all locking devices are properly locked.

Spirit level

- Make sure that the spirit level is clearly visible to the operator and works correctly.

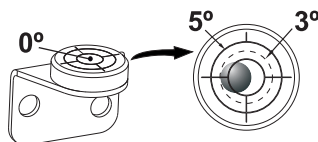

Shafts, shaft locking, bearings and bushings

- Check that the shafts, shaft locking, bearings and bushings are undamaged and working properly.

Emergency stop buttons

- Check that the emergency stop buttons are undamaged and working properly.

Levers on the main control valve

- Check that the levers operate smoothly.
- Check that the levers return to neutral position.

**NOTE**

Check the levers on both side of the vehicle

Controller [option]

- Do a check of the controller functionality.
- Check that the levers operate smoothly.
- Make sure that there are not warnings and/or faults.

TRI (Transport Report Interface)

- Make sure that there is not any acoustic signal and/or warning LED active when the crane and stabiliser system are in transport position.
- Make sure that the acoustic signal and the warning LED are active when you start operating the stabiliser system or unfolding the boom system.

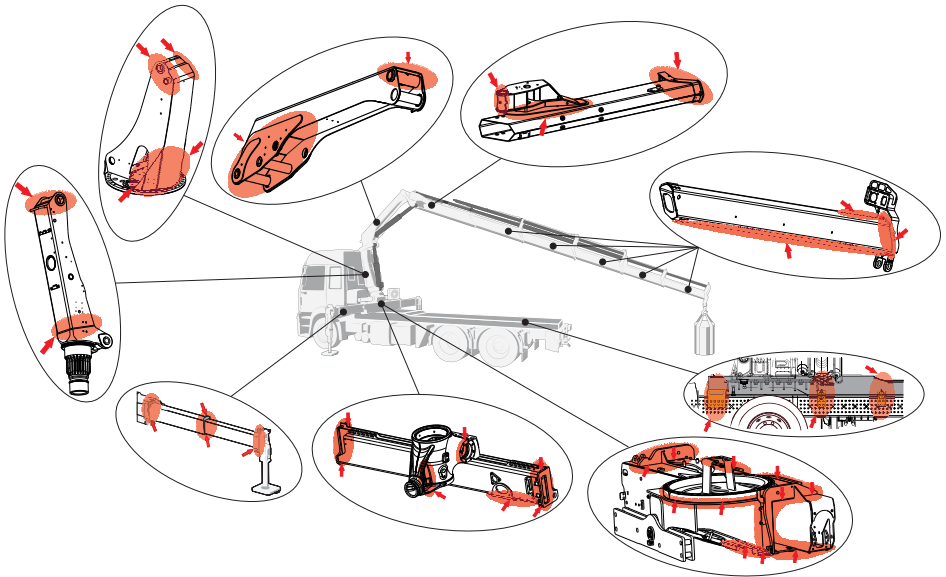
Crane structure

- Check for damage to the crane structure (e.g. any formation of cracks, including the paint).

**DANGER**

In the event of damage that presents a safety risk:

- Do not use the crane.
- Have the damage repaired immediately by an authorised service workshop.

Hooks

Always keep the hook clean. Use a cloth to wipe away any dirt.

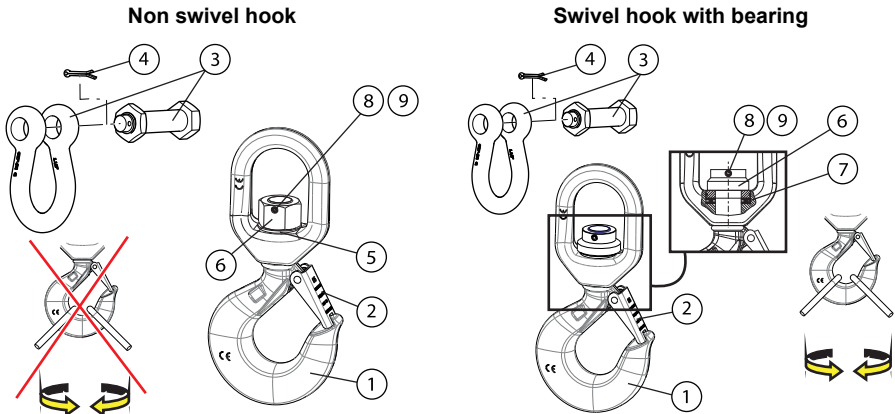

Before every working shift:

- Do an inspection of the general conditions of the Hook (1) for deformation (stretched, cracked, twisted, excessive wear...) and surface damages with significant depth (such as from chemicals or heat).
- Do an inspection of the bow shackle (3) for damage/deformation.
- Do an inspection of the two Spring/Roll pins (8) and (9) that are in place and properly retaining the central hook nut (6).
The two Spring/Roll pins (8) and (9) should be in place and nearly flush with the outer edge of the hook nut (6) on both sides.
- Do an inspection of the spring-loaded safety Latch (2). The Latch must close the entire throat opening.
- Verify that the bow shackle (3) and cotter/safety pin (4) are in place.
- Verify that the plane bearing/washer (5) or the swivel (7) is in good condition.
- Do a general inspection for deformation and operation of the remaining items: clevis, swivels, washers, nuts, pins...
- Lubricate the hook according to the chapter "Lubrication of the hooks".



DANGER

In the event of damage or worn to prevent a safety risk:

- Do not use the hook.
- Have the damage repaired immediately by an authorised service workshop.

Add-on equipment and separate accessories

- Maintain all add-on equipment, separate accessories, auxiliary equipment etc. according to the instructions supplied with it.

Electrical components and controller [option]

- Check that these are in good condition.
- Make sure that the horn works correctly (only if the controller is installed).

Hydraulic system and oil level in the tank

- Check that there are no leaks from the hydraulic hoses, lines and connections.
- Make sure that all security seal wires (Ex. LHV, dump valves, etc...) are not broken. Always go to/contact an authorised service workshop when the seal wire has been broken.
- Check oil level in the tank. If necessary, fill to correct level.

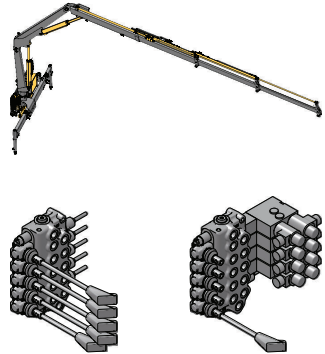

NOTE

Always place the vehicle on level ground with the crane in transport position while checking the oil.

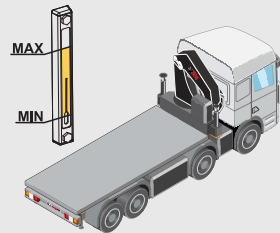

8.3.2. Monthly inspection and maintenance

**NOTE**

Refer to the monthly inspection checklist at the end of this manual to photocopy.

In addition to the daily inspection, carry out the following tasks each month:

Piston rods

- In cases where the cylinder piston rod is exposed to pollution due to the parking location, the chromed surfaces must be cleaned and oiled to prevent corrosion. This needs to be done regularly.

Pivot pins and bushes

- Inspect all the pivot pins and bushings for the crane boom and cylinders for damage, clearance, etc.

Bolts and screw fixings

- Check that bolt and screw fixings are tight. If not, contact an authorised service workshop
- Make sure that the fixing bolts are not broken or loose. Check that they are in good condition and in place.

Cables and sensors

- Check that cables and sensors are in good condition.

Lubrication schedule

- Carry out the lubrication according to the instructions.

Upper and lower column bearing

- Check that the upper and lower column bearing is lubricated sufficiently.

Hydraulic system

- Check that the hydraulic pump attachment screws are tightened.
- Check if the oil in the hydraulic system needs to be changed, or have it tested by a workshop or a specialist.

Add-on equipment etc.

- Maintain all add-on equipment, auxiliary equipment etc. according to the instructions supplied with it.

Paint condition

- Check that there is not any paint damage on your crane. Have the damage repaired immediately by an authorised service workshop.

8.3.3. Annual maintenance

Take the crane, at least once a year, to an authorised service workshop for inspection and maintenance.

The workshop must carry out the following maintenance tasks at least once a year.

Hydraulic oil

- Change the hydraulic oil.



NOTE

If the workshop is equipped and the personnel prepared to do a test of the oil quality and think that the oil change is not needed, they can postpone it on their own responsibility.

Oil tank filter and filler cap

- Change the filler cap.
- Replace filter.

Slewing system

- Make sure that there are not unusual movements, noises, excessive clearance, etc... between the base and column when operating the crane.

Hooks

- Replace missing or faulty parts on link assembly: shafts, safety pins and nuts.
- Replace the hook for a new one if the hook is damaged.
- Replace the hook for a new one if its weight allowed marking is damaged.
- Replace the latch assembly if it is damaged, missing or malfunctioning.
- Replace the hook for a new one if the clevis/link shaft, centring spacer, or split clevis retaining nuts are missing or damaged.
- **Non swivel hook:** replace the two spring/roll pins and the plane bearing with new ones at least once a year.

8.4. Lubrication

8.4.1. General greasing of the cranes

Incorrect or insufficient lubrication of a crane is the number one cause of premature failure.

Lubricate all parts in the crane marked with the symbol 



WARNING

Before and after a long stop of the crane, lubrication is necessary (especially after a winter shutdown).

**WARNING**



Follow the lubrication schedule exactly. If you do not do so, you can cause serious damage to the crane and to add-on equipment.

Procedure:

1. Shut down the crane.
2. Make sure that all the lubrication points are clean before lubricating. Dirt can damage the parts.
3. Lubricate all points in each section.
4. Operate the crane through the full cycle for each section. Moving the lubricated parts is very important to get the full and correct lubrication of all moving components.
5. Shut down the crane and repeat the lubrication.
6. Lubrication is finished when the grease spills out from the ends. Clean the excess grease.

**WARNING**

Personnel must not try to work on a moving/activated crane as there is a risk of serious injury or death.

You will need different tools based on the area to lubricate: a pressure grease pump , an oiler , a brush .

**CAUTION**

When you use pressure grease pumps, open the plastic safety guard of the nipple and close it at the end.

Greases

- Use molybdenum-disulfide grease (for bronze-made components).
- Use lithium-based grease AGIP MUEP2 or equivalent, for the booms and stabiliser extensions.

**CAUTION**

Do not mix greases with different characteristics. If you change from one kind to another, fully remove the old grease by applying a large quantity of the new one.

Recommended greases:

Use Nilex 2 (Nils)

Alternative:

FUCHS LUBRITECK: STABYL AX 2, AGIP: ROCOL SAPPHIRE AQUA 2, AGIP: AC 2.

Lubricating oil:

For oil lubrication, use class SAE 30 (maximum ambient temperature 20 °C) and class SAE 90 (for ambient temperatures higher than 20 °C).

8.4.2. Lubrication schedule

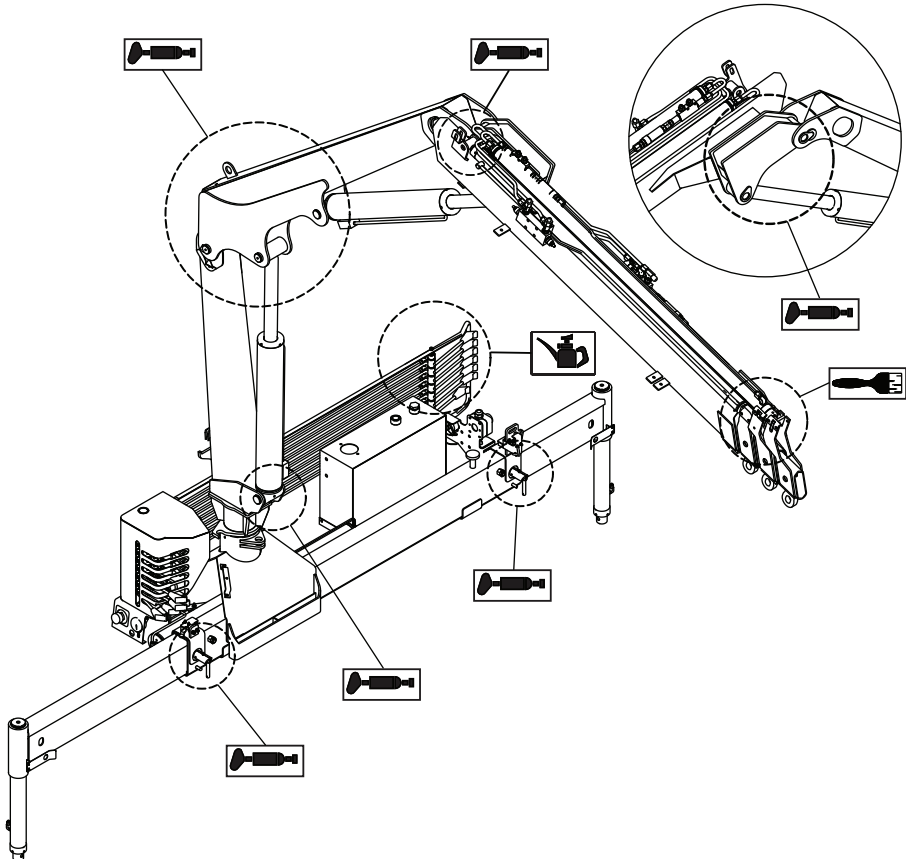

8.4.3. Lubrication of the upper and lower slewing bearing

- Lubricate the bearings with a little grease.
- Slew the crane a little.
- Again lubricate with a little grease. Repeat, until the column has been slewed round completely.

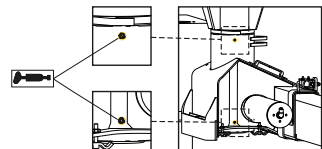

8.4.4. Lubrication of the boom system

Clean the surfaces and remove with a spatula all abrasive material (dirt, sand, shavings), and where possible, the old grease.

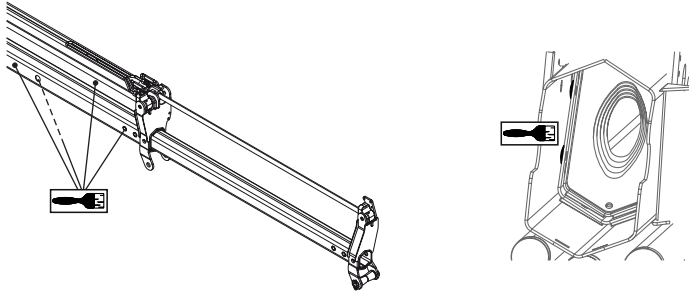
**Procedure:**

- Grease externally the extensions in the low part (less in the upper and side parts).
- Grease internally the extensions in the upper part (less in the lower and side parts).
- In order to internally grease, use the side holes in the extensions (if fitted) and the back closing plate slots.
- Grease the sliding block area (if fitted) with the extensions retracted and also through two specific greasing points.

**NOTE**

To prevent or correct malfunctions or the "stick-slip" of the boom extensions operation, we recommend lubricating the lower part of the extensions.

If you have any doubt, please contact your Effer representative.

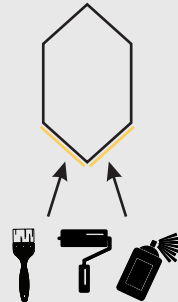

8.4.5. Grease on the stabiliser extensions

Grease the lower sliding surfaces on the stabiliser extensions.

When accessible, grease inside the stabiliser beam in the upper and lower sliding surfaces.

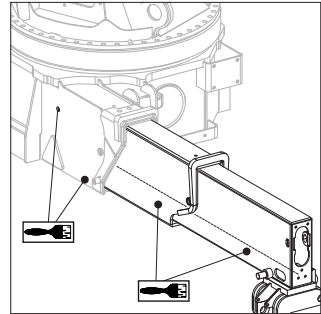

8.4.6. Lubrication of the hooks

Hooks with plane bearing

1. Lubricate with oil the spring of the latch.
2. If the hook cannot rotate easily without load, grease the plane bearing surfaces.
Use a heavy duty penetrating spray grease, type "ZEP 2000" or equivalent quality.

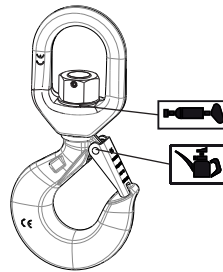

Hooks with swivel

1. Lubricate with oil the spring of the latch.
2. If the hooks cannot rotate easily with load, grease the swivel bearing.
Use a bearing grease, type "Texaco Multifak EP 2" or equivalent quality.

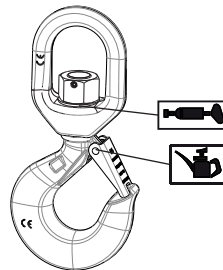

8.5. Checking and topping up oil levels

8.5.1. Oil tank / Hydraulic oil

Checking of the oil level of the tank

1. Place the crane and stabiliser legs in the transport position.
2. Place the vehicle on level ground.
3. Check the oil level in the tank.
4. If the oil level is too low, top up with hydraulic oil.

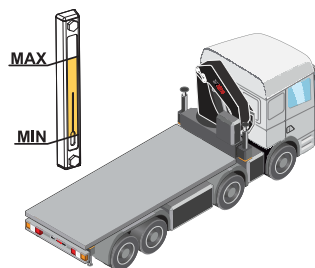

Oil filling / Top up

1. Make sure that the required equipment to fill the tank is fully clean.
2. Put the crane in the parked position.
3. Clean the area around the oil filler cap.
4. Fill with oil up to the max level indicator.

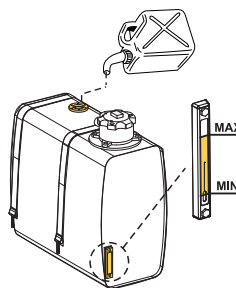

CAUTION

- Never fill the tank completely, because during operation the volume of the oil could expand as the temperature increases.
- Never use recycled oil!

Filling the oil tank with hydraulic oil



CAUTION

The oil used for filling must be clean. Do not mix different oils (a mixture will change the oil properties).

Hydraulic oils must have been dealt with according to cleanliness requirements ISO 4406: -/16/13.



Hydraulic oil that is approved for EFFER products must comply with one of the following standards or equivalents:

- DIN 51524 part 2HLP
- ISO L-FD
- ISO L-HM

Verify with the supplier that the quality and performance of the hydraulic oil complies with the previous standards.

When changing from mineral oil to a non-polluting synthetic oil, or when changing to biodegradable oil, contact an authorised service workshop.

Recommended hydraulic oils

| | ISO VG 32 | ISO VG 46 | ISO VG 68 |
|-------------------|---|---|--|
| Examples | Tellus S2 V32 Super 32 Hydrol L-HV 32 | Shell TELLUS T 46 Texaco RANDO HDZ46 Agip ARNICA 46 | Mobil SHC 526 |
| Where to use them |  |  |  |

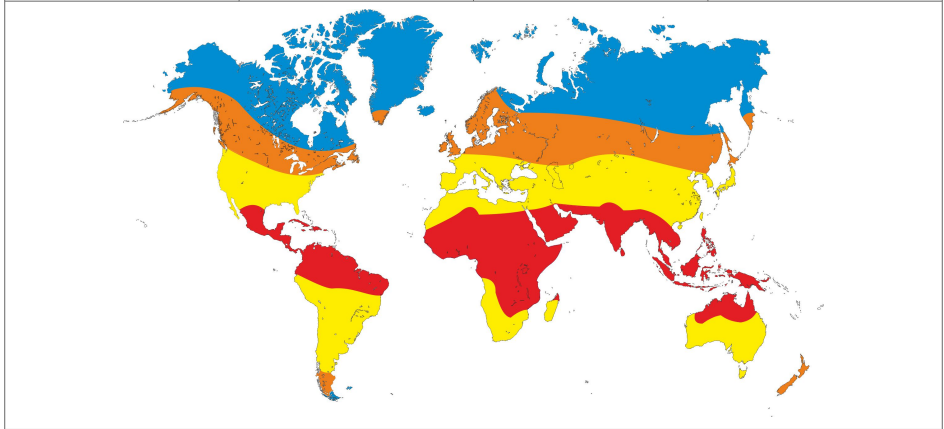

Viscosity of oil

The viscosity of the oil is of great importance to achieve high efficiency of the hydraulic system.

The naming of the oil in the table below: 32, 46 or 68 tells the viscosity of that oil at 40°C (104°F) (reference temperature).

| Viscosity of oil at 40°C (104°F) | Temperature range |
|---|--------------------------------|
| 32 | -25°C to 75°C (-13°F to 167°F) |
| 46 | -15°C to 90°C (5°F to 194°F) |
| 68 | -5°C to 90°C (23°F to 194°F) |

The recommended viscosity during normal working conditions is between 20 and 70 cSt.

Effer strongly recommends an oil working temperature below 80°C (176°F). If necessary consider an extra oil cooler or heater.

**NOTE**

If you need to work at a temperature below -25°C (-13°F), contact an authorised service workshop.

Environmentally Friendly Oil

The environmentally friendly oils recommended for EFFER products are ester based synthetic hydraulic fluids (synthetic ester).

**CAUTION**

Vegetable oils do not meet Effer requirements and must not be used.

After filling the tank

1. Operate each crane function to its end positions.
2. Put the crane into parked position.
3. Check and top up the oil tank to max level on the tank gauge.
4. Bleed the air from the hydraulic system.

**NOTE**

- Ensure the waste oil is disposed of safely and in accordance with local environmental regulations.
- The oil can be hot and cause injury.

8.6. Replacement of filters

Filter cartridges must be replaced by an authorised service workshop.

- after the first 50 hours operation
- then after every 1000 hours operation
- or at least once a year.

**CAUTION**

Dirt will damage the hydraulic system.

8.6.1. Inlet filter for remote-controlled cranes

This filter has no indicator. The location is on the main control valve.

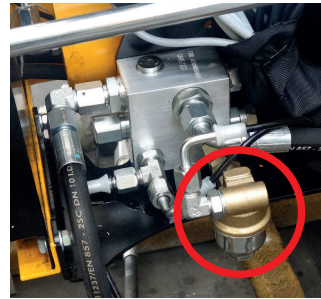

8.6.2. Breathing filter

This filter has no indicator. The location is in the filler cap in the oil tank.

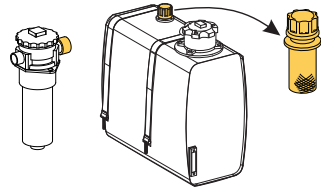

8.7. Bleeding air from the hydraulic system

Bleed the air from the hydraulic system:

- after changing the hydraulic oil
- after working on the hydraulic system
- if your crane works slowly or jerkily
- if your crane has not been used for a long time



WARNING

Air in the hydraulic system can lead to faults and damage

To bleed the air from the hydraulic system, proceed as follows:

1. Slowly extend and retract each stabiliser leg to its end position at least two times.
2. Set stabiliser system in working position and operate the crane out of parked position.
3. Slew the crane slowly in each direction to the slewing stop at least twice.
4. Slowly raise and lower the 1st and the 2nd boom to its end position at least twice.
5. Slowly extend and retract the boom extensions to their end position at least twice.
6. Slowly operate each hydraulically operated add-on equipment such as grapple, pallet fork, etc. to their end position at least two times.



CAUTION

Do not keep the lever engaged at the end position of each movement.

7. Check the oil level in the tank and top up if necessary.

9. Decommissioning

9.1. Decommissioning a crane



NOTE

Only qualified companies can remove the crane from the truck and dispose of it.

Cranes are designed and manufactured taking the environment into consideration. Environmental requirements and soundness have been considered when selecting the raw materials. The metal parts are designed to achieve a light and durable construction; this includes the selection of higher-quality grades of steel. When the crane is decommissioned at the end of its service life, years from now, waste will be created, which must be utilised and disposed of correctly. The crane must be decommissioned properly. Most of the crane's raw materials can be recycled.

Follow the regulations of the local authorities!

- Oil and grease must not be spilled on to the ground or released into the environment!
- Drain the oil from hydraulic cylinders, valves and hoses.

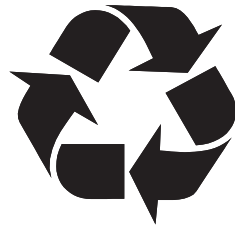

Sort the waste

- Deliver the metal parts for recycling, for reuse as raw material. These are load-bearing, structures manufactured from steel or cast iron, hydraulic cylinders and lines drained of oil, directional control valves, shafts, bearing bushes, control levers, small parts.

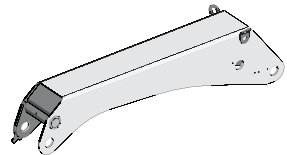

Energy waste can be utilised by incinerating it at a proper waste incineration plant.

- Spiral wraps, manufactured from polyethene, plastic, bearings (cleaned of lubricants) used in the column, beam system etc, manufactured from polyamide plastic.

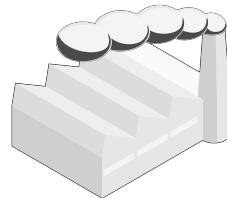

Unsorted waste should be delivered to a landfill.

- Drained hydraulic hoses, electrical wires, control cables, seat, hydraulic cylinder seals, lights, small plastic and rubber parts.



Hazardous waste is delivered to a collection point for hazardous waste.

- Oils: hydraulic oil, transmission oil from the slewing system
- Solid lubricants: greases from the joints and journal bearings
- Other waste containing oils and greases: hydraulic oil filters.



European Union—Disposal Information

This symbol identifies the parts of your crane that need to be disposed of separately from household waste according to EU legislation. When one of these parts reaches the end of its life, take it to a collection site designated by local authorities. Responsible collection and recycling help protect natural resources, the environment, and human health.

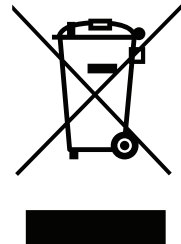

10. Technical Data

10.1. Load plate table

The Installer must fill in the valid meters (m) and kilos (kg) in this table, following instructions given in the Installation instructions.

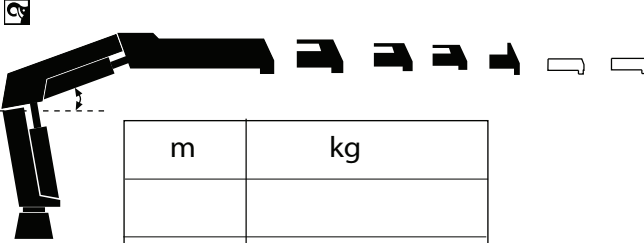

| m | kg |
|---|----|
| | |
| | |
| | |
| | |
| | |
| | |
| | |
| | |
| | |
| | |
| | |
| | |
| | |
| | |

The enclosed Technical Data must be stored together with this Operator’s manual.

10.2. Identification of the loader crane

The information below is to be filled in by the installer. The same information will be found on the serial number plate on the crane:

Mark: EFFER

(0) Machine Type: CRANE

(1) Model:

(2) Serial number:

(3) Manufact. year:

(4) CE mark

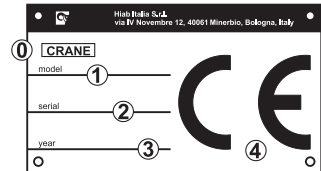

10.3. Daily inspection checklist

| Operator | | | Document ID: | |
|---|---|---|--------------|----------|
| Crane s/n: | | | Date: | |
| DAILY INSPECTION | ✓ | ✗ | ⊘ | Comments |
| Presence of signs and symbols | | | | |
| Locking devices | | | | |
| Spirit level | | | | |
| Shafts, locking shafts, bearings and bushings | | | | |
| Crane structure | | | | |
| Hooks | | | | |
| Add-on equipment and separate lifting accessories | | | | |
| Electronic components | | | | |
| Security seal wires | | | | |
| Hydraulic system and oil level in the tank | | | | |
| Rack and pinion | | | | |
| FUNCTIONAL TESTS | | | | |
| Emergency stop buttons | | | | |
| Levers on the main control valve | | | | |
| Levers on the controller (if present) | | | | |
| Horn and flashing light test | | | | |
| TRI (Transport Report Interface) | | | | |
| If you find a fault that prevents you from operating the crane safely, contact an authorised service workshop. Do not try to repair the fault, it can cause you injury or you can damage the equipment. | | | | |
| Permission to reproduce this checklist is granted; however please note that only the original document owned by Hiab will contain necessary amendments and updates. Hiab shall not be held liable if the copy in your possession does not contain the latest changes. | | | | |

10.4. Monthly inspection checklist

| | | | | |
|---|---|---|---------------------|-----------------|
| Operator | | | Document ID: | |
| Crane s/n: | | | Date: | |
| MONTHLY INSPECTION | ✔ | ✘ | ⊘ | Comments |
| Piston rods | | | | |
| Pivot pins and bushes | | | | |
| Bolts and screw fixings | | | | |
| Cables and sensors | | | | |
| Lubrication schedule | | | | |
| Upper and lower column bearing | | | | |
| Pump attachment screws | | | | |
| <p>If you find a fault that prevents you from operating the crane safely, contact an authorised service workshop. Do not try to repair the fault, it can cause you injury or you can damage the equipment.</p> <p>Permission to reproduce this checklist is granted; however please note that only the original document owned by Hiab will contain necessary amendments and updates. Hiab shall not be held liable if the copy in your possession does not contain the latest changes.</p> | | | | |

This page is intentionally left blank.