

70X X4



JIB Operator's Manual GB

737 4249



Congratulations!

You are now the owner of a quality Product manufactured by Hiab (part of Cargotec Corporation).

The aim of this manual is to help you handle, maintain your crane safely and with full satisfaction.

This Manual provides detailed information about your Product, its control systems and its practical management and maintenance.

Please read the complete Manual carefully and make sure that you understand its contents. Please also carefully familiarise yourself with your Product before you start to use it.



Help us to improve this manual. Please send your comments and suggestions to **documentation@hiab.com**

This manual applies to JIBs that operate with the crane control system SPACE
X4 from serial number:

00000407, 108662.

2023-03

This page is intentionally left blank.

Table of Contents

1. Introduction	7
1.1. This Operator's Manual is intended for operators of cranes with a JIB	7
1.2. The JIB	8
1.3. The Machinery Directive 2006/42/EC	9
1.4. The Machinery (Safety) Regulations 2008	10
1.5. Identification of JIB	10
2. Structure and parts of the JIB	11
2.1. JIB Components	11
3. Safety precautions and warnings	12
3.1. Safety precautions and warnings	12
4. Hydraulic connections	14
4.1. Hydraulic quick couplings [option]	14
4.2. Hydraulic quick couplings (MULTI-X) [option]	16
5. Operation	17
5.1. Dismantling JIB (without hoist)	17
5.2. Fitting the JIB (without hoist)	18
5.3. SAF Semi Automatic Folding [option]	19
5.4. Operate the crane with JIB (without hoist) out of parked position	21
5.4.1. EFFER iX.355 HP	22
5.5. Working with the JIB	22
5.5.1. Operation with the 5th and 6th functions	22
5.5.2. How to achieve sufficient reach	23
5.6. SAF Semi Automatic Folding [option]	24
5.7. Operate the crane with a JIB (without hoist) to parking position	26
5.7.1. EFFER iX.355 HP	27
5.8. OLP and JIB	28
5.9. Manual extensions [option]	29
5.9.1. Fitting and dismantling manual JIB extensions	30
5.10. Special hook application without dismantling the JIB	33
6. Operation with hoist	34
6.1. Operation with hoist	34
6.1.1. Displacing the hoist manually	34
6.2. Dismantling the JIB (with hoist)	36
6.2.1. Dismantling JIB (with hoist TC2L/TI2L) with integrated pulleys	36
6.3. Fitting the JIB (if hoist)	37
6.3.1. Connect the hoist TC2L/TI2L with integrated pulleys	37
6.4. Operating a crane with JIB and hoist out of parked position	38
6.5. Operating a crane with JIB and hoist to parking position	40
6.6. Operating a crane with hoist (without JIB)	42
6.6.1. Operating with hoist TC2L/TI2L with integrated pulleys (without JIB) ..	42
7. Maintenance	44
7.1. Maintenance and service	44
7.2. Lubrication	44
7.3. Lubrication schedule JIB	45
7.4. Faults	46
8. Technical Data	47

This page is intentionally left blank.

1. Introduction

1.1. This Operator's Manual is intended for operators of cranes with a JIB

This manual describes

- operation
- maintenance and faults

This manual is a supplement to the Operator's Manual for your type of crane.



DANGER

If you have not studied the complete Operator's Manual for your crane and for your JIB carefully, it could lead to fatal accidents or serious damage.

Therefore you should:

- Study the entire Operator's Manual carefully.
- Operate the crane only after you have done so.
Follow the directions for use, operation and maintenance of the crane exactly.



NOTE

The manufacturer reserves the right to change specifications, equipment, operating instructions and maintenance instructions without prior notice.

1.2. The JIB

The JIB is an interchangeable equipment that extends the crane boom. Use the JIB so as to be able to reach further.

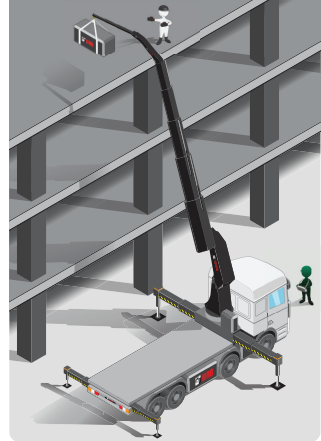

NOTE

- Load diagram signs for the JIB are placed on the column.
- See the Technical Data for the precise technical information concerning the JIB on your crane.

Crane configurations where JIB 70X can be fitted:

model	JIB 70X
EFFER iX.355 HP	E-5-6

1.3. The Machinery Directive 2006/42/EC

- The Declaration of Conformity, delivered with the equipment contains (1):
- Business name and full address where the interchangeable equipment is manufactured (2):
 Factory addresses:
 Hiab Cranes S.L.U. Pol. Ind. Malpica, calle E, 86 50016 Zaragoza, Spain
 Cargotec Poland Sp. z o. o. Ul. Metalowa 2, 73-102 Stargard, Poland
 Hiab Italia S.r.l. Via IV Novembre 12, 40061 Minerbio (BO), Italy
- Description and identification of the equipment (3):
 Mark
 Type: see chapter Identification of the interchangeable equipment.
 Serial number
 Manufact. year
 Declaration of which provisions the equipment fulfils.
- Name and address of the person authorised to compile the technical file (4):
 Name
 Address
- Identity and signature of the person who drawn up the declaration (5):
 Name
 Position
 Date and Signature

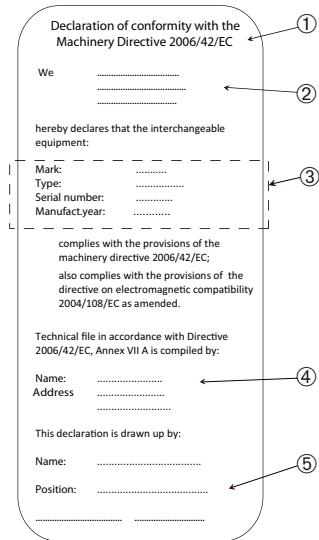

Declaration of conformity with the Machinery Directive 2006/42/EC

We _____

_____ hereby declares that the interchangeable equipment:

Mark: _____

Type: _____

Serial number: _____

Manufact. year: _____

_____ complies with the provisions of the machinery directive 2006/42/EC; also complies with the provisions of the directive on electromagnetic compatibility 2004/108/EC as amended.

Technical file in accordance with Directive 2006/42/EC, Annex VII A is compiled by:

Name: _____

Address: _____

This declaration is drawn up by:

Name: _____

Position: _____

1.4. The Machinery (Safety) Regulations 2008

- The Declaration of Conformity, delivered with the equipment contains (1):
- Business name and full address where the interchangeable equipment is manufactured (2):
 Factory addresses:
 Hiab Cranes S.L.U. Pol. Ind. Malpica, calle E, 86 50016 Zaragoza, Spain
 Cargotec Poland Sp. z o. o. Ul. Metalowa 2, 73-102 Stargard, Poland
 Hiab Italia S.r.l. Via IV Novembre 12, 40061 Minerbio (BO), Italy
- Description and identification of the equipment (3):
 Mark
 Type: see chapter Identification of the interchangeable equipment.
 Serial number
 Manufact. year
 Declaration of which provisions the equipment fulfils.
- Name and address of the person authorised to compile the technical file (4):
 Name
 Address
- Identity and signature of the person who drawn up the declaration (5):
 Name
 Position
 Date and Signature

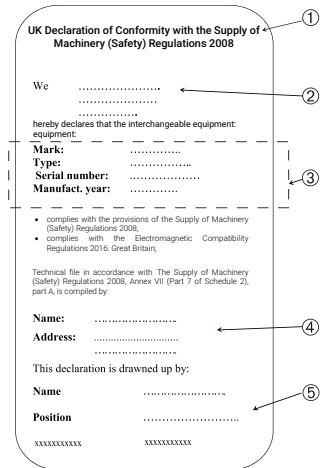

UK Declaration of Conformity with the Supply of Machinery (Safety) Regulations 2008

We

 hereby declares that the interchangeable equipment:
 equipment

Mark:
 Type:
 Serial number:
 Manufact. year:

• complies with the provisions of the Supply of Machinery (Safety) Regulations 2008;
 • complies with the Electromagnetic Compatibility Regulations 2016 Great Britain.

Technical file in accordance with The Supply of Machinery (Safety) Regulations 2008, Annex VII (Part 7 of Schedule 2), part A, is compiled by:

Name:
 Address:

This declaration is drawn up by:

Name
 Position

XXXXXXXXXX XXXXXXXXXXXX

1.5. Identification of JIB

Description and identification of the JIB:

Mark:

Type: **JIB 70X**

Serial number:

Manufact. year:

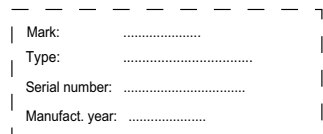

Mark:
 Type:
 Serial number:
 Manufact. year:

2. Structure and parts of the JIB

2.1. JIB Components

The JIB consists of the following components:

- (1) JIB boom
- (2) JIB cylinder
- (3) JIB extension
- (4) JIB extension cylinder
- (5) JIB manual extension [option]
- (6) JIB support

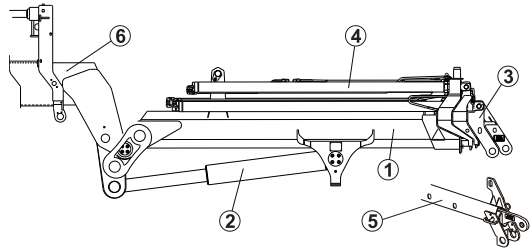

3. Safety precautions and warnings

3.1. Safety precautions and warnings



DANGER

If you have not studied the Operator's Manual for your crane carefully, it could lead to fatal accidents or serious damage.



DANGER

When using the JIB, always connect the JIB to the SPACE Safety System.

Without this connection, the OLP protection for the JIB is not activated.

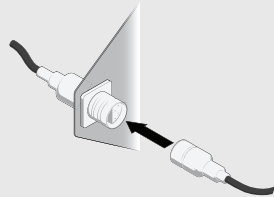

DANGER

Load diagram JIB

Load diagram signs on the column show the maximum loads in the working zone for your JIB.

Never exceed the JIB's maximum permitted load!

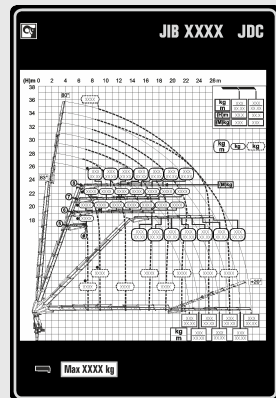

NOTE

When you use equipment such as hoist, JIB, lifting accessories or interchangeable equipment and their necessary components, you add weight to the load. Because of this, the load you can lift is less heavy.



DANGER

Always check that the JIB is firmly attached before use.



WARNING

The operation of a crane with JIB is different from the operation of a crane without it. For example, there is a big difference when you need to put the crane in and out of transport position.

To prevent damage to the JIB: study this instruction carefully before operating the crane with the JIB.

4. Hydraulic connections

You can disconnect a hydraulic line or a hose only for specific operator's tasks (for example, disconnecting the interchangeable equipment).



DANGER

- STAY AWAY from oil leaks in the hydraulic system! Oil in the hydraulic system is under high pressure, can spill, be very hot and cause you injury.
- Do not replace any hydraulic hoses or lines yourself.



WARNING

- Switch off the control system and the PTO before connecting or disconnecting the electrical and hydraulic connections.
- Keep the electrical and hydraulic protection caps and plugs in good condition and store them in a safe place.

4.1. Hydraulic quick couplings [option]

Hydraulic quick couplings allow a faster connection and disconnection of each hydraulic line.



WARNING

- Switch off the control system and the PTO before connecting or disconnecting the connectors.
- Always remove/attach first the electrical connection before the hydraulic connection.
- Keep the electrical and hydraulic protection caps and bypass in good conditions and store them in a safe place.

To connect the hydraulic quick couplings you must:

1. Switch off the control system.
2. Disengage the PTO.
3. Remove the protection caps.
4. Connect the respective hydraulic quick couplings taking care with the corresponding identification:
 - Yellow and blue collars = 5th function
 - Red and green collars = 6th function

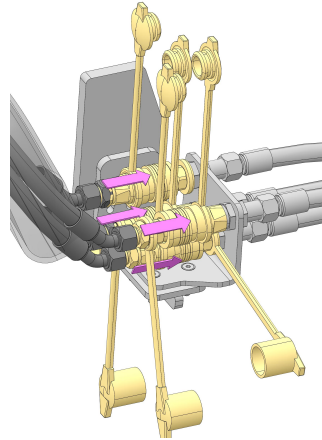

NOTE

To prevent damage, do not change the hydraulic quick couplings position.

5. Reconnect the PTO and switch on the system, if needed.
6. Do a functional test of all movements of the interchangeable equipment to verify that there are no mistakes in the connections.

To disconnect the hydraulic quick couplings you must:

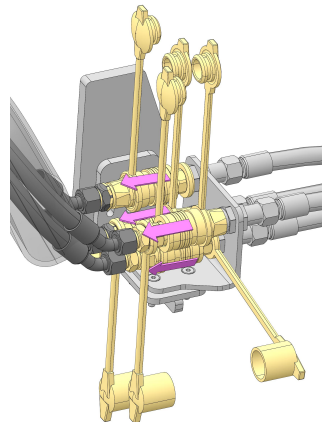
1. Switch off the control system.
2. Disengage the PTO.
3. Disconnect the hydraulic couplings, and protect them with protective caps.
4. Reconnect the PTO and switch on the system, if needed.
5. Operate the crane to verify that all functions work correctly.



4.2. Hydraulic quick couplings (MULTI-X) [option]

Hydraulic quick couplings allow the connection of several hydraulic lines at the same time.



WARNING

- Switch off the control system and the PTO before connecting or disconnecting the connectors.
- Always remove/attach first the electrical connection before the hydraulic connection.
- Keep the electrical and hydraulic protection caps and bypass in good conditions and store them in a safe place.

To connect the hydraulic quick couplings you must:

1. Switch off the control system.
2. Disengage the PTO.
3. Remove the protection caps.
4. Turn the lever to the upper position to allow the hydraulic connection.
5. Connect the hydraulic quick coupling MULTI-X (1).
6. Turn the lever to the lower position (2). Make sure that the lever locks the connection correctly.
7. Reconnect the PTO and switch on the system, if needed.
8. Do a functional test of all movements of the interchangeable equipment to verify that there are no mistakes in the connections.

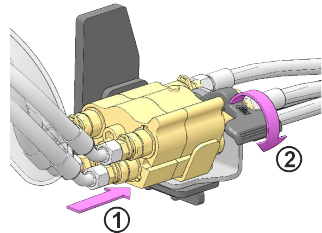

To disconnect the hydraulic quick couplings you must:

1. Switch off the control system.
2. Disengage the PTO.
3. Turn the lever to the upper position (1).
4. Disconnect the hydraulic couplings (2), and protect them with protective caps.
5. Turn the lever to its initial position.
6. Reconnect the PTO and switch on the system, if needed.
7. Operate the crane to verify that all functions work correctly.

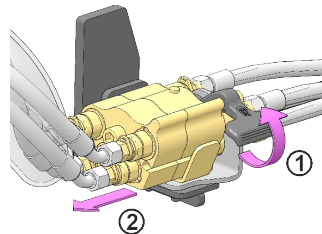

5. Operation

5.1. Dismantling JIB (without hoist)



WARNING

Take care, when fitting and dismantling the JIB that your fingers do not get trapped. Dismantle the JIB carefully. Rough and careless handling can damage the JIB.

1. Retract the JIB extensions.
2. Extend second boom cylinder totally.
3. Extend the crane extension at least 600 mm.
4. Check that the supports (1) are mounted. Lower the JIB very carefully on to a level surface. Check that the tip of the crane and the JIB are not damaged in this operation. Release the pressure on the hydraulic system: Operate the levers for the 5th and 6th functions.
5. Disconnect the JIB from the hydraulic system.
6. Disconnect the JIB from the SPACE control system:
Disconnect the cable contact (2).
Put the plugs (3) back in the JIB cable end and in the crane cable end.
7. Remove the securing plate (4) and pull out the locking pin (5).
8. The JIB is now free from the crane. Carefully retract the crane extension away from the JIB.
9. Fit the hook on the crane.

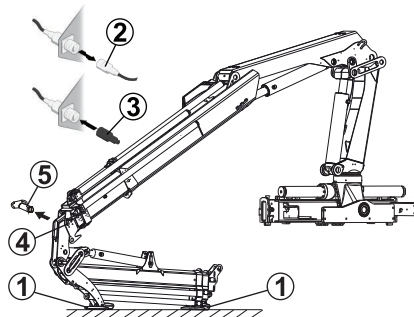
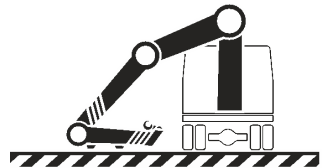

5.2. Fitting the JIB (without hoist)



WARNING

Take care, when fitting and dismantling the JIB that your fingers do not get trapped.

1. **Dismantle the hook** from the crane.
2. **Fitting the JIB**
 Position the crane boom immediately above the JIB.
 Lower the boom carefully and fit the extension into the JIB.
 Put the locking pin (1) in place and fit the securing plate (2).
 Remove the supports (3).

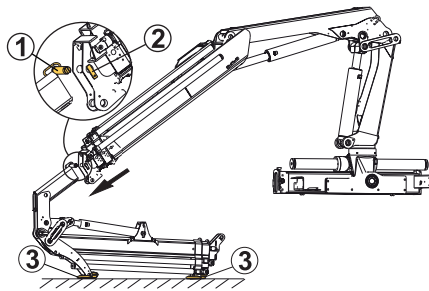
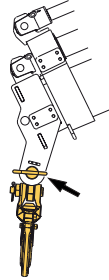

3. Push in the stop button and switch off the operating system with the ON/OFF button.
4. Release the pressure on the hydraulic system: Operate the levers for the 5th and 6th functions.

Connect the JIB



WARNING

Clean the quick connect coupling on the hydraulic system and on the JIB. Dirt will cause serious damage to the hydraulic system.

1. Connect the JIB to the hydraulic system.
2. Connect the JIB to the SPACE safety system:
 - remove the plug (1)
 - connect the JIB contact (2)

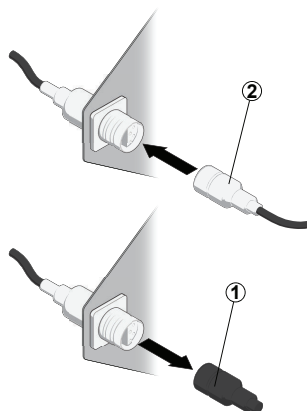

DANGER

When using the JIB, always connect the JIB to the SPACE Safety System. Never use the JIB without connecting it to the SPACE. Otherwise the OLP for the JIB is not activated.



DANGER

Check that the JIB is firmly attached!

Check that the locking pin and the securing plate are firmly attached

5.3. SAF Semi Automatic Folding [option]

SAF is a feature which allows the operator to fold or unfold the boom system in one single sequence using only one lever.



Unfold the boom system semi automatically



WARNING

Never use SAF with mounted tools.

WARNING

Make sure there is enough space for the boom system to unfold/fold semi automatically. If the situation does not allow SAF, use crane mode to operate the boom system out of/into the parked position.

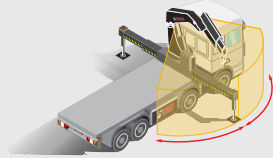
WARNING

If your crane has **manual extensions**, make sure that they are totally retracted or removed before operating the crane with the SAF feature.



WARNING



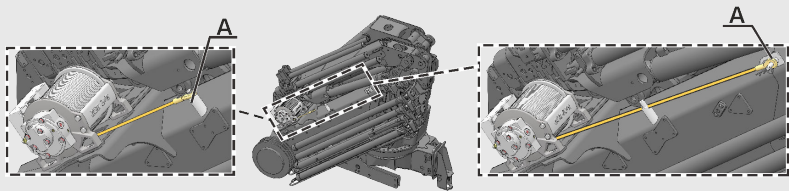

If your crane has **long JIB support**, make sure that it is totally retracted before operating the crane with the SAF feature.

WARNING

If your crane has a **hoist**, change from hoist to hook operation.

Make sure that the rope is on the 2nd boom support and it does not pass through any pulley. If not, remove the rope from the pulleys and put it in the 2nd boom support **(A)** before operating the crane with the SAF feature.



1. Select the menu for SAF on the controller.
2. If SAF is not configured in a separate crane menu, push the button  to activate it.
3. Operate the lever on the controller until the boom system has been fully unfolded:
 - XSDrive  or 
 - CombiDrive  or 

**DANGER**

Pay careful attention when using this feature.

Always maintain eye contact when operating the crane.

During this movement, the boom system will unfold itself, release the lever immediately if the boom system is about to:

- Hit a person
- Hit an object
- Hit a moving obstacle that suddenly comes closer to the crane.

4. If SAF is not configured in a separate crane menu, push button  to deactivate it.

5.4. Operate the crane with JIB (without hoist) out of parked position

**DANGER**

Position the stabiliser extensions and legs on the ground.

**WARNING**

Always operate a crane with a JIB very carefully. The space for moving the boom system and the JIB is limited. Make sure that there is enough space available. Careless or rough crane movements can seriously damage the crane and the JIB.

5.4.1. EFFER iX.355 HP



NOTE

SAF option is possible with this crane configuration.

1. Turn the pin (1) and pull it out to unlock the 1st boom.
2. Operate the 2nd boom against the 1st boom (2).
3. Retract the extensions (3).



CAUTION

Do these operations slowly to not damage the parking pin “A” or the parking support “B”.

4. Raise the 1st boom (4) until BDA allows you to operate the 2nd boom or $\beta > 135^\circ$.
5. Raise the 2nd boom (5).
6. Raise the JIB (6). Make sure that tip of the JIB passes underneath the rear part of the first boom.
7. Slew the crane to the working position.

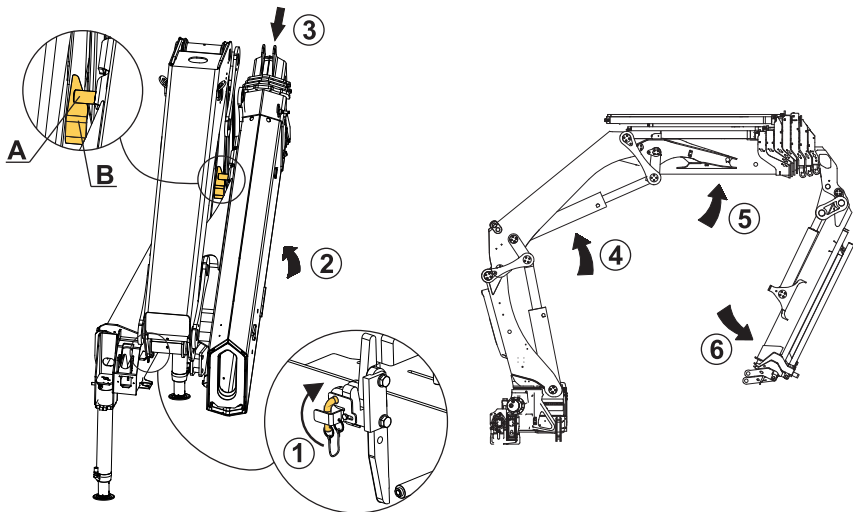

5.5. Working with the JIB

5.5.1. Operation with the 5th and 6th functions

The JIB is operated with the 5th and 6th functions of the control valve or from the remote control.

Crane Speed

With the boom system fully extended: work at low crane speed.



WARNING

If the JIB extensions are extended, do not push the JIB tip against the ground. You will damage it.

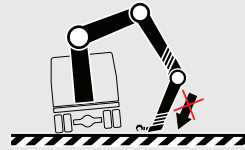

5.5.2. How to achieve sufficient reach

1. First extend the crane extensions completely.
2. Then extend the JIB as far as needed.

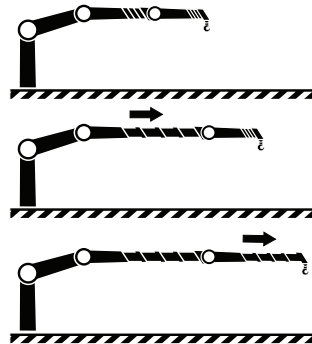

WARNING

Do not slew the crane until the load is completely free of the ground.



DANGER

Never exceed the JIB's maximum permitted load.



WARNING

In high boom positions, retract the JIB extensions before retracting crane extensions. Otherwise, unexpected side movements of the boom system can occur, causing dangerous movements of the load.

5.6. SAF Semi Automatic Folding [option]

SAF is a feature which allows the operator to fold or unfold the boom system in one single sequence using only one lever.



Fold the boom system semi automatically



WARNING

Never use SAF with mounted tools.



WARNING

Make sure there is enough space for the boom system to unfold/fold semi automatically. If the situation does not allow SAF, use crane mode to operate the boom system out of/into the parked position.

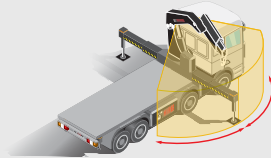

WARNING

If your crane has **manual extensions**, make sure that they are totally retracted or removed before operating the crane with the SAF feature.



WARNING







If your crane has **long JIB support**, make sure that it is totally retracted before operating the crane with the SAF feature.

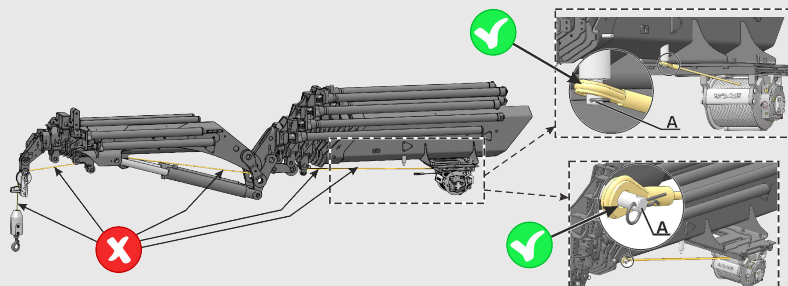

WARNING



If your crane is equipped with a hoist, change from hoist to hook operation. Displace the hoist, if needed, to the outside position before operating the crane to parking position with JIB and hoist. Make sure that the rope is on the 2nd boom support and does not pass through any pulley. If not, remove the rope from the pulleys and fit it in the 2nd boom support (A) before operating the crane with the SAF feature.







1. Select menu for SAF on the controller.
2. If SAF is not configured in a separate menu, push button  to activate it.
3. Operate lever on the controller until the extensions are fully retracted:
 - XSDrive  or 
 - CombiDrive  or 
4. Confirm on the controller that the extensions are totally retracted:
 - XSDrive 
 - CombiDrive 



NOTE

If you stop the SAF sequence, remember that when you start it again, the crane will not move. You must push the confirm button/lever  or  on the controller to continue with the sequence. Push this button/lever once, because it activates/deactivates the SAF sequence. So, if you push the button twice you will need to push it again to continue with the SAF sequence.

5. Continue operating lever on the controller until the boom system is totally folded:
 - XSDrive  or 
 - CombiDrive  or 



DANGER

Pay careful attention when using this feature.

Always maintain eye contact when operating the crane.

During this movement, the boom system will fold itself, release the lever immediately if the boom system is about to:

- Hit a person
- Hit an object
- Hit a moving obstacle that suddenly comes closer to the crane.

6. If SAF is not configured in a separate menu, push button  to deactivate SAF.

5.7. Operate the crane with a JIB (without hoist) to parking position



WARNING

Always operate a crane with a JIB very carefully. The space for moving the crane boom and the JIB is limited. Make sure that there is enough space. Careless, rough crane movements can seriously damage the crane and the JIB.

1. Retract the JIB extensions first.
2. Then retract the crane extensions.
3. Move the transport securing pin (P), if fitted from (S) to (T) to lock the JIB extensions (if fitted).

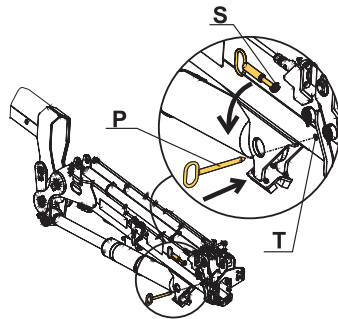
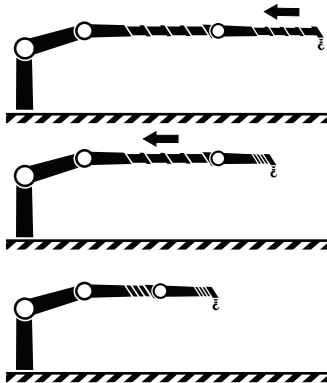

5.7.1. EFFER iX.355 HP



NOTE

SAF option is possible with this crane configuration.



NOTE

If the crane has OPS, press the button "B" and hold it in, while carrying out points 5-7.

1. Retract the JIB extensions (1). Then retract the crane extensions (2).
2. Raise the first boom (3) until BDA allows you to operate the second boom or $\beta > 135^\circ$.
3. Slew the crane to parking position. Check that arrows "A" are aligned.
LED for the parking control **P** will light blue on the User Interface [Option].
4. Operate the JIB towards the second boom (4), leaving an angle of 30° approx. between the JIB and first boom extension. Take care not to damage any interchangeable equipment and/or optional crane component, if mounted.

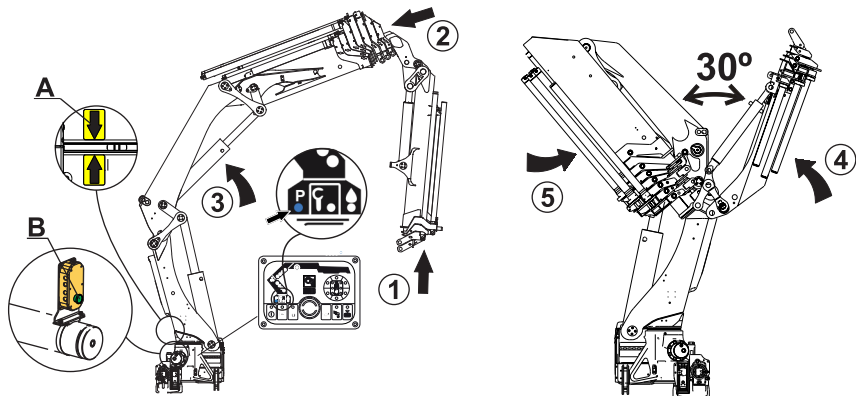

5. Operate the second boom against the first boom (5) and reach the vertical position as shown in the figure.

- Lower the JIB completely on to the second boom (6) until the parking support "C" rests on the second boom and the hook is placed on the second boom support "D", if fitted.

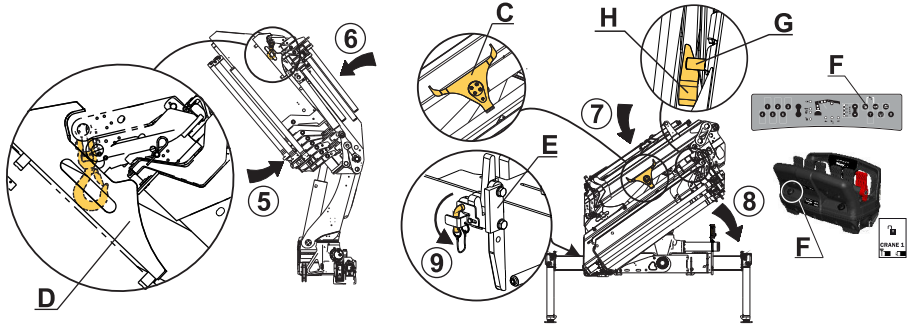

- Lower the first boom (7) until it rests on the slot on the crane base "E".
 - Release OLP.
- Press the button "F" on the controller for remote control operation or the button on the User Interface for manual operation.
- Lower the second boom slowly (8) until the parking pin "G" rests on the parking support "H" on the column.
 - Always lock the first boom with the locking pin (9).
 - Fold in the hook if support "D" is not fitted.

5.8. OLP and JIB

OLP prevents the JIB from being overloaded:

When the load is close to the rated capacity the OLP gives a pre-warning.

- The cylinder pressure LED's flash red.

At the rated capacity, a new warning is given.

- The indicator LED's light up red.

Prohibited movements are stopped. Move the levers to neutral, and then only operate permitted (load reducing) functions.

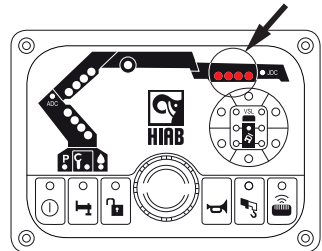

NOTE

Do not operate heavy loads with the extensions fully retracted. In the event of OLP it is an advantage to be able to retract the extensions.



DANGER

Never use the OLP override to overload the crane deliberately! Never exceed the values given on the load plate.

**NOTE**

In case of a crane breakdown, the use of OLP release will be part of the investigation. If the use of OLP release is too excessive it might affect warranty.

5.9. Manual extensions [option]

Operation with manual extensions

- Always extend the hydraulic extensions first, then the manual extensions.
- The use of manual extensions should be restricted to the longest outreach needed. When this reach is not needed, the manual extension should be retracted.

**DANGER**

Do not stand in front of moving parts. They may eventually move and cause injuries.

**WARNING**

Never use the SAF feature with the manual extensions extended.

**CAUTION**

To operate the crane to transport position, do not forget either dismantle manual extension or place manual extension completely into the last hydraulic extension.

5.9.1. Fitting and dismantling manual JIB extensions



DANGER

Do not stand in front of moving parts. They may move and cause injuries.

Fitting

1. Place the manual extension (1) into the last JIB extension until it is possible to place the locking device (2) in holes (3) (working position) or (4) (transport position).
2. Fix the manual extension, by locking the pin and the locking device (2).
3. Fit the security supports (5).

Dismantling

1. Dismount the security supports (5).
2. Remove the locking device and the pin (2).
3. Remove carefully the manual extension (1) from the last JIB extension.

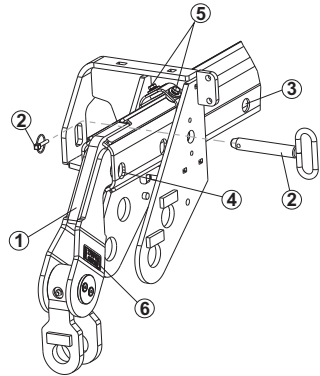

DANGER

Never exceed the value given on the manual extension load plate (6). Manual extension may break and cause injuries.



CAUTION

To operate the crane to transport position, do not forget either dismantle manual extension or place manual extension completely into the last JIB extension.

Activate and de-activate OLP for manual extensions on the User Interface



WARNING

You must switch the OLP on and off manually for additional manual extensions!

Activate:

Push button  on the User Interface.

The manual extensions are now included in the OLP protection. The lifting capacity will be reduced automatically. The lamp for  lights up on the User Interface.

De-activate:

Push the button again. The lamp for  goes out.



Activate and de-activate OLP for manual extensions on the XSDrive controller



WARNING

You must switch the OLP on and off manually for additional manual extensions!

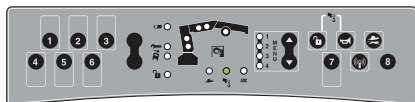

Activate:

Push buttons  and  on the controller.

The manual extensions are now included in the OLP protection. The lifting capacity will be reduced automatically. The lamp for  lights up on the User Interface.

De-activate:

Push the buttons again. The lamp for  goes out.



Activate and de-activate OLP for manual extensions on the CombiDrive controller



WARNING

You must switch the OLP on and off manually for additional manual extensions!

Activate:

Push both button (1) and (2) until symbol  on the centre display is lit.

(The lamp for manual extension is lit on the User Interface.)

The manual extensions are now included in the OLP protection. The lifting capacity will be reduced automatically.

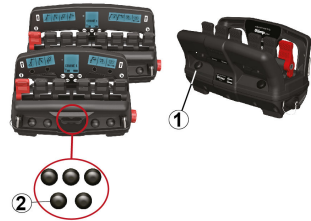

De-activate:

Push the button (1) and (2) again. The symbol  on the centre display goes out.

(The lamp for manual extension goes out on the User Interface.)

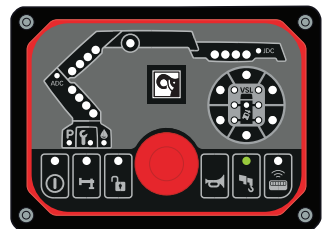
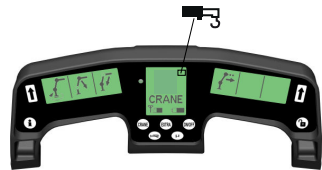

5.10. Special hook application without dismantling the JIB

This is the special hook application to handle heavy loads without dismantling the JIB.

1. Raise the first boom (1).
2. Retract the JIB extensions (2).
3. Remove the hook from the tip of the JIB.
4. Operate the JIB against the second boom (3).
5. Place the hook "A" in the hole "B" located on the first boom of the JIB. Fix the hook, by the pin and the locking pin "C".
6. Attach the load to the hook "A".

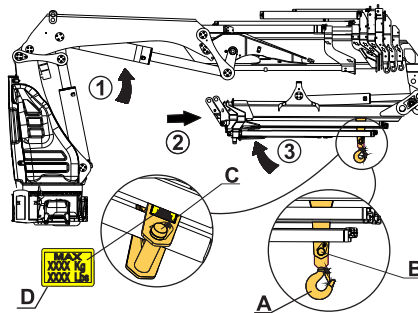

DANGER

Never exceed the value given on the crane optional components, interchangeable equipment or lifting accessories load plates "D". They may break and cause injuries.



CAUTION

To operate the crane to transport position, do not forget to dismantle the hook "A" from the hole "B".

6. Operation with hoist

6.1. Operation with hoist

If a hoist is mounted on the crane the rope is guided by pulleys mounted on the extensions and on the JIB.

6.1.1. Displacing the hoist manually



WARNING

The hoist must work in line with the pulleys.

To displace the hoist from the outside position to the central position:

1. Turn 90° clockwise the lever (1), then the shaft (2) is unlocked.
2. Push the hoist to the central position with the handles (3).
3. Turn 90° counterclockwise the lever (1), to lock the shaft (2).

To displace the hoist from the central position to the outside position:

1. Turn 90° clockwise the lever (1), then the shaft (2) is unlocked.
2. Pull the hoist to the outside position with the handles (3).
3. Turn 90° counterclockwise the lever (1), to lock the shaft (2).

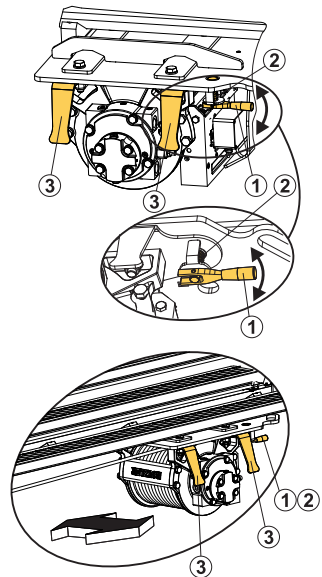

DANGER

Before lifting load with the hoist, be sure that the hoist is locked with the lever (1) in working position.

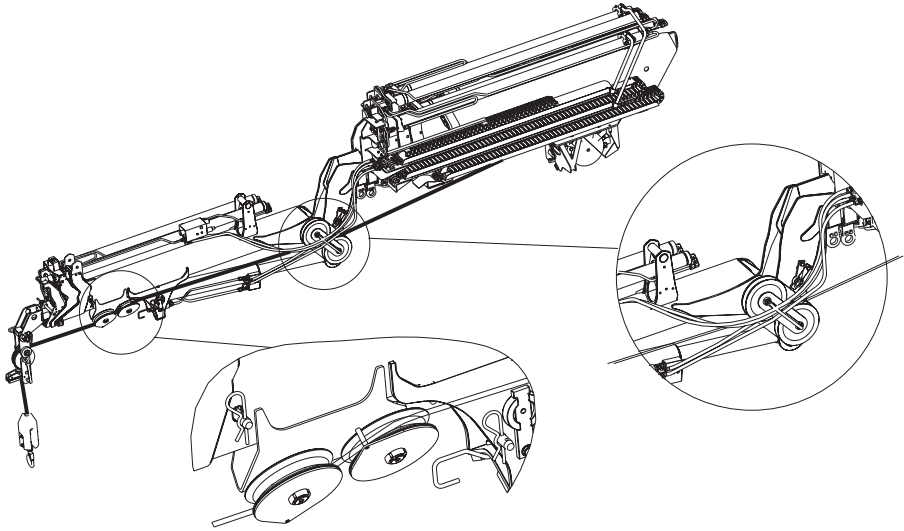
Integrated pulleys:

Guide the rope as shown in the picture.

It is not necessary to dismantle pulleys when operating the crane with JIB in to or out of parking position.

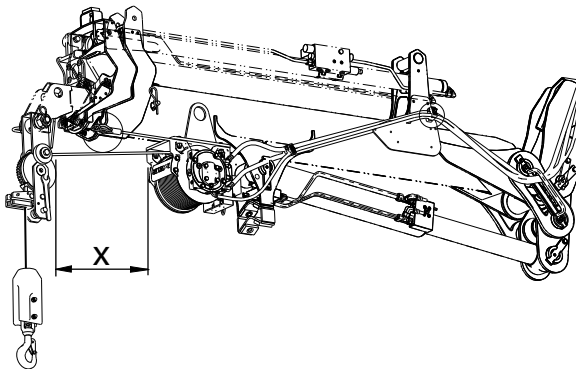
Hoist TC1/T11 assembled on the JIB

During operation the distance X must be minimum **2 metres** to get proper winding of the rope. This will prevent damage to the hoist and rope.

6.2. Dismantling the JIB (with hoist)

6.2.1. Dismantling JIB (with hoist TC2L/TI2L) with integrated pulleys

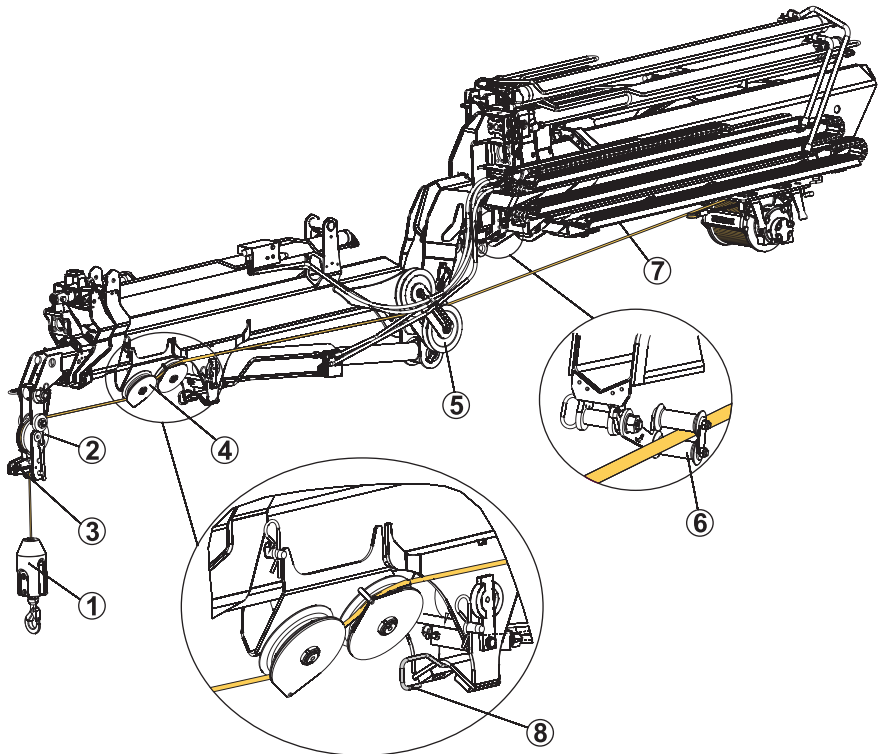

1. Remove hook and counter weight (1) if mounted, or unfasten the rope from support (8) if no hook present/used. In this case follow step 3 directly.
2. Pulley (2):
 - a. Remove the securing pin and the locking pin (3).
 - b. Remove the rope.
 - c. Reinstall the locking pin and the securing pin (3).
3. Remove the rope through pulleys (4) and (5).
4. If the crane has 6 boom extensions or more, remove the rope through the cable guide (6) at the 4th crane boom.
5. Roll the rope at the hoist.



WARNING

To obtain a correct rolling up, the rope has to be guided. A wrong rolling up can result in damage on rope or unexpected movements.

6. Place the rope end in support (7), then tighten lightly.
7. Follow the operation: "Dismantling the JIB (without hoist)".
8. Once the JIB is dismantled, the hoist must be placed in the central position.

6.3. Fitting the JIB (if hoist)

Fit the JIB according to: Fitting the JIB (without hoist) and connect the hoist, explained below according to your crane model.

6.3.1. Connect the hoist TC2L/TI2L with integrated pulleys

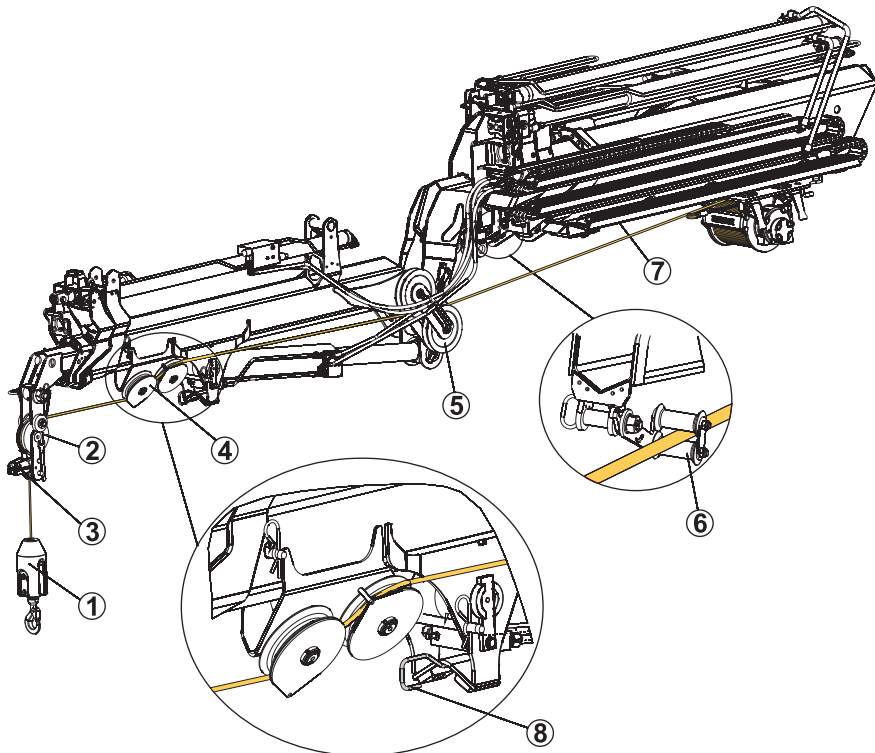

WARNING

The hoist must work in line with the pulleys.

1. Remove the rope end from the support (7).

WARNING

To obtain a correct rolling up, the rope has to be guided. A wrong rolling up can result in damage on rope or unexpected movements.

2. Unroll the rope from the hoist.
3. If the crane has 6 boom extensions or more, pass the rope through the cable guide (6) at the 4th crane boom.
4. Pass the rope through pulleys (4) and (5). To fasten the rope end to support (8), do it directly from pulleys (4).
5. Fit link and pulley (2), if it is not fitted.
6. Pulley (2):
 - a. Remove the securing pin and the locking pin (3).
 - b. Install the rope.
 - c. Reinstall the locking pin and the securing pin (3).
7. Install the hook and counter weight (1).

6.4. Operating a crane with JIB and hoist out of parked position

Operating a crane with JIB and hoist TC2L/TI2L out of parked position with integrated pulleys

Rope fitted to the JIB support

1. Release the rope from the support (1) on the JIB.

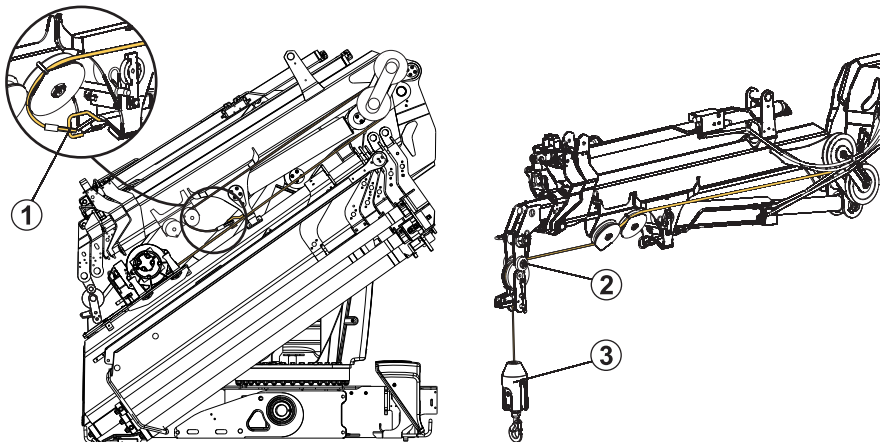
DANGER

Before moving the boom system, unroll the rope far enough to release the crane from the transport lock.

**NOTE**

Keep the rope loose. Use the controller to roll/unroll the rope while you are raising the crane

2. Follow the procedure: Operating the crane with JIB (without hoist) out of parked position, according to your crane model.
3. Fit link and pulley (2) and pass the rope through the pulley, if they are not fitted.
4. Fit the hook and the counter weight (3).
5. The hoist must work in line with the pulleys, displace it if necessary.

Rope fitted to the 2nd boom support

1. Release the rope from the support (1) on the 2nd boom.

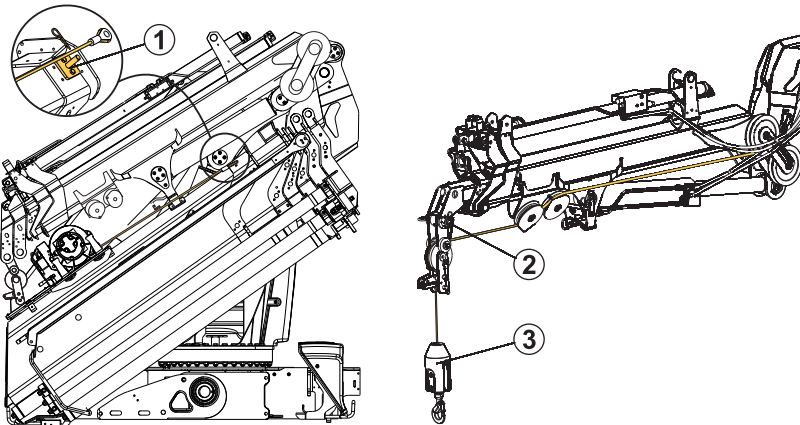
**DANGER**

Before moving the boom system, unroll the rope far enough to release the crane from the transport lock.

**NOTE**

Keep the rope loose. Use the controller to roll/unroll the rope while you are raising the crane

2. Follow the procedure: Operating the crane with JIB (without hoist) out of parked position, according to your crane model.
3. Fit link and pulley (2) and pass the rope through the pulley, if they are not fitted.
4. Follow the procedure: Connect the hoist TC2L/TI2L with integrated pulleys, according to your crane model.
5. Fit the hook and the counter weight (3).
6. The hoist must work in line with the pulleys, displace it if necessary.

6.5. Operating a crane with JIB and hoist to parking position

EFFER iX.355 HP

To parking position:

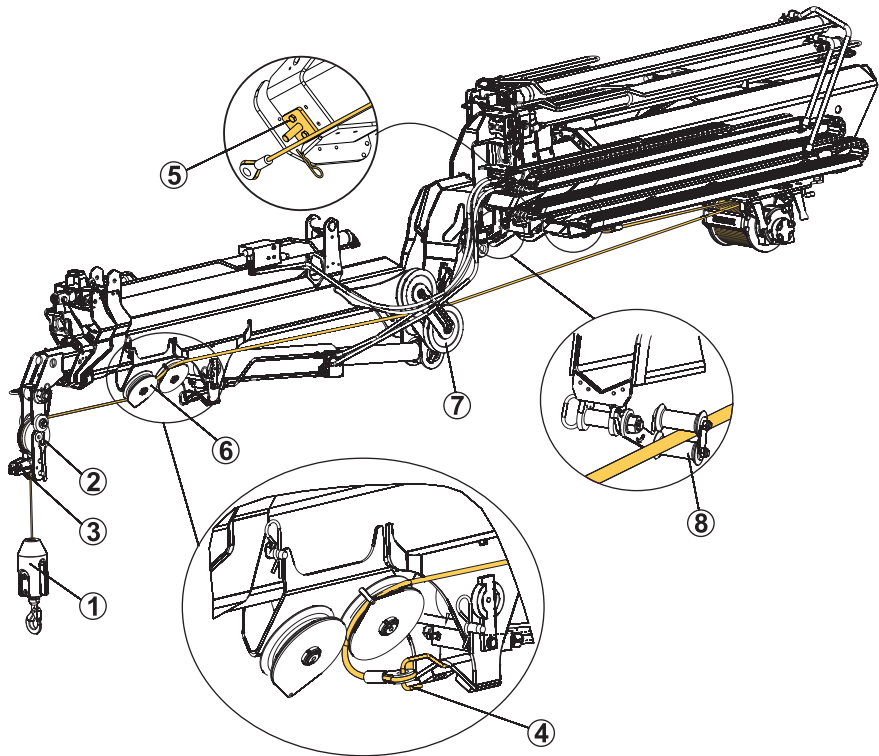

1. Dismantle the hook and the counterweight (1).
2. Remove the rope through the pulley (2):
 - a. Remove the securing pin and the locking pin (3).
 - b. Remove the rope.
 - c. Reinstall the locking pin and the securing pin (3).
3. Fit the rope in the required support:

Support (4) on the JIB.

Once the rope is free from pulley (2), fasten the rope end directly from pulleys (6) to the support (4), then tighten lightly.

Support (5) on the 2nd boom.

 - a. Once the rope is free from pulley (2), remove the rope through pulleys (6) and (7).
If the crane has 6 boom extensions or more, remove the rope through the cable guide (8) at the 4th crane boom.

- b. Once the rope is free from pulley (2), remove the rope through pulleys (6) and (7).
- c. Place the rope end in support (5), then tighten lightly.

**CAUTION**

If JIB fitted with the cylinder protection, the cable guide (8) must be removed before operating the crane to parking position.

**NOTE**

During the following operations keep the rope loose. Use the controller to roll/unroll the rope while you are folding the crane.

Take care, not to damage hoist.

4. Follow the procedure: Operate the crane with JIB (without hoist) to parking position, according to your crane model.

Lowering the JIB on to the parking support can differ depending on the crane configuration:

With the top roller fitted on the JIB:

- a. Before lowering the JIB completely on to the parking support, extend the JIB extensions a bit.
- b. Check that the pulley kit on the tip of the JIB has no contact with the second boom.
- c. Retract completely the JIB extensions. The pulley kit will rest on the protection of the second boom as shown in the picture.
- d. Lower the JIB completely on to the parking support.

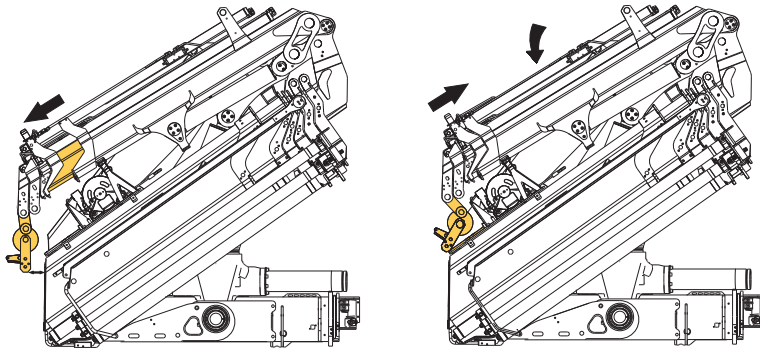
**With movable hoist support:**

Lower the JIB until the parking support "A" rests on the second boom.

Without movable hoist support:

Lower the JIB until it rests on the parking support "B" of the hoist.

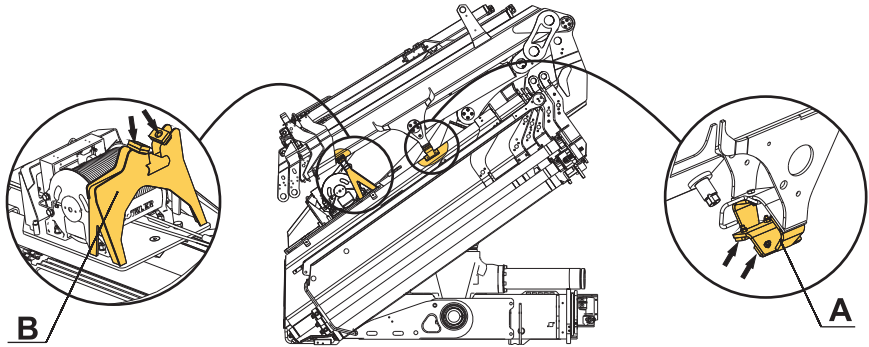

6.6. Operating a crane with hoist (without JIB)

6.6.1. Operating with hoist TC2L/TI2L with integrated pulleys (without JIB)

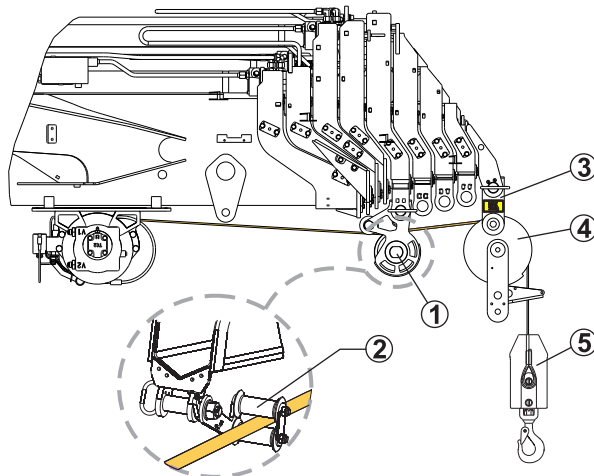

Once the JIB has been dismantled:

1. If the crane has 6 or more extensions, install the intermediate pulley (1) at the 4th extension of the crane.

NOTE

Use this intermediate pulley only for crane operations with hoist. To use the hoist with the JIB again, pulley (1) must be replaced by the cable guide (2).

2. Install the link assembly kit (3) in the last extension of the crane.

3. Install the hoist pulleys kit (4).
4. Install the hook and the counter weight (5).



WARNING

The hoist must work in its central position.

7. Maintenance

7.1. Maintenance and service

Follow the instructions in this manual and the Operator's Manual for your crane.

7.2. Lubrication

General greasing of the cranes

Incorrect or insufficient lubrication of a crane is the number one cause of premature failure.



WARNING

Before and after a long stop of the crane, lubrication is absolutely necessary. This is especially important after a winter shutdown.



WARNING

Follow the lubrication schedule exactly. If you do not do so, you can cause serious damage to the crane, interchangeable equipment and/or optional crane component.

Procedure:

1. Shut down the crane.
2. Make sure that all the lubrication points are clean before lubricating. Dirt can damage the parts.
3. Lubricate all points in each section.
4. Operate the crane through the full cycle for each section. Moving the lubricated parts is really important to get the full and correct lubrication of all moving components.
5. Shut down the crane and repeat the lubrication.
6. Lubrication is finished when the grease spills out from the ends. Clean the excess grease.



WARNING

Personnel should never attempt to work on a crane that is moving. Serious injury or death will occur if you try to work on an activated/moving crane.



CAUTION

When you use pressure grease pumps, open the plastic safety guard of the nipple and close it at the end.

Greases

Use lithium-based grease containing EP additives (consistencies 2 and 3 are recommended, depending on the climate).

**CAUTION**

Do NOT grease with graphite or molybdenum-disulphide additives.

Recommended greases:



BP LS EP 2, ESSO UNIWAY EP2 N, AGIP GR MU/EP3, NYNÄS UNIFETT EP.

Alternative:

Use a Teflon grease spray to lubricate the extensions and mobile parts.

7.3. Lubrication schedule JIB

Lubricate all the marked points.

	Lubricate after every 16 hours of operation.
	Lubricate after every 50 hours of operation.
	Grease after every 50 hours of operation.

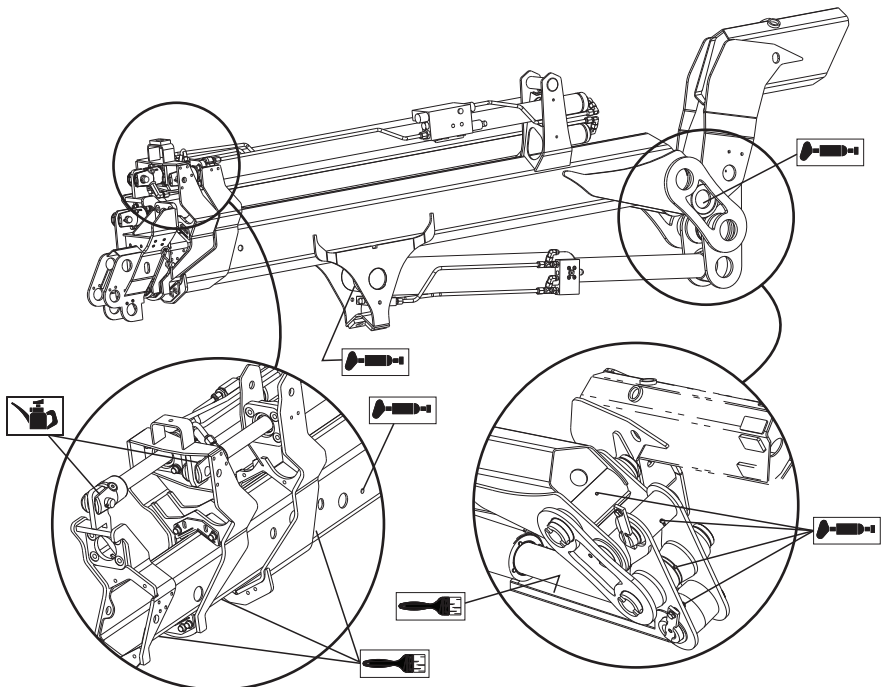

7.4. Faults

If faults occur with the JIB, contact an authorised service workshop.



NOTE

- when you use the JIB, connect the JIB connector (1) to the SPACE control system.
- after you remove the JIB: put the plug (2) in the SPACE connection for the JIB and crane.

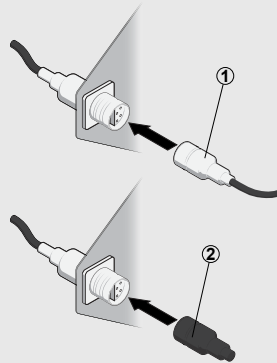

WARNING

Never try to repair the JIB yourself!

8. Technical Data

Documentation

The Technical Data for the JIB shall be printed out when installed on the crane.

The Operator's manuals for the crane and the JIB should be stored together with Technical Data for both.

This page is intentionally left blank.

© EFFER

All rights reserved.

No part of this publication may be reproduced or copied in any form or by any means without written permission from EFFER.

EFFER is part of Cargotec Corporation.



EFFER